

# Advance Buffer Vessels for Ground Source Heat Pump Systems

## Installation and Commissioning Manual



Copyright ©2020 Kensa Heat Pumps Ltd

## Contents Page

Section	Description	Page
<b>1.....</b>	<b>Safety Information.....</b>	<b>3</b>
1.1.....	Access.....	3
1.2.....	Lighting.....	3
1.3.....	Tools and Consumables.....	3
1.4.....	Handling.....	3
1.5.....	Residual Hazards.....	3
1.6.....	Freezing.....	3
1.7.....	Disposal/decommissioning.....	3
<b>2.....</b>	<b>General Product Information.....</b>	<b>4</b>
2.1.....	Equipment Delivery and Handling.....	4
2.2.....	Buffer Vessel Dimensions and Arrangements.....	5
2.3.....	General Specification.....	7
<b>3.0.....</b>	<b>Typical Schematics.....</b>	<b>8</b>
3.1.....	Twin Coil Cylinder with GSHP (Space Heating and DHW Production).....	8
3.2.....	Buffer Vessel Installation with the Shoebox Heat Pump.....	9
<b>4.0.....</b>	<b>Installation.....</b>	<b>10</b>
4.1.....	Electrical Connections.....	11
<b>5.0.....</b>	<b>Commissioning.....</b>	<b>11</b>
<b>6.0.....</b>	<b>Warranty.....</b>	<b>12</b>

## 1. Safety information

Safe operation of this unit can only be guaranteed if it is properly installed and commissioned in compliance with the manufacturer's requirements. General installation and safety instructions for pipeline and plant construction, as well as the proper use of tools and safety equipment must also be complied with.

Manufacturer:-  
Advance Appliances Ltd  
Unit 4  
Coppice Side Industrial Estate  
Brownhills  
Walsall  
West Midlands  
WS8 7EX  
Tel: 01543 377723  
Fax: 01543 360620

The product is designed and constructed to withstand the conditions encountered during normal use. Use of the product for any other purpose, or failure to install the product in accordance with these Installation and Commissioning Instructions, could damage the product, will invalidate the warranty, and may cause injury or fatality to personnel.

### 1.1 Access

Ensure safe access before attempting to work on the product. Arrange suitable lifting gear if required.

### 1.2 Lighting

Ensure adequate lighting, particularly where detailed or intricate work is required.

### 1.3 Tools and consumables

Before starting work ensure that you have suitable tools and / or consumables available.

### 1.4 Handling

Manual handling of large and /or heavy products may present a risk of injury. Lifting, pushing, pulling, carrying or supporting a load by bodily force can cause injury particularly to the back. You are advised to assess the risks taking into account the task, the individual, the load and the working environment and use the appropriate handling method depending on the circumstances of the work being done.

### 1.5 Residual hazards

Many products are not self-draining. Take due care when dismantling or removing the product from an installation.

### 1.6 Freezing

Provision must be made to protect products which are not self-draining against frost damage in environments where they may be exposed to temperatures below freezing point.

### 1.7 Disposal/Decommissioning

A life time decommissioning service for this product is available. This is available on a return to base basis (carriage at users' cost).

## 2. General Product Information

This manual explains how to install and commission an Advance Buffer Vessel System with a Kensa Heat Pump.

Buffer vessels are simply a tank that contains a volume of water, increasing the overall volume of the heating distribution system. This extra volume of water is designed to absorb any extra heat generated by the heating appliance in low load conditions, which the building does not yet require.

If the building cannot absorb the extra heat generated the return temperature to the heating appliance (in this case a heat pump) will increase and will turn off. If the temperature drops in the water returning to the heating appliance, then it will turn itself back on. If this cycling occurs at a greater frequency than the minimum run time for the appliance this is classed as short cycling. The aim of a buffer vessel is to remove the possibility of any short cycling of the heating appliance.

For a heat pump the minimum run time is set by the number of compressor starts within an hour. For a single compressor heat pump this is usually around four. This means that typically for low loads which are below a quarter of the maximum heat output short cycling can occur.

The size of the buffer vessel and the temperature at which it operates will determine its effectiveness and efficiency.

Kensa's system designs are specifically designed to be able to operate without a buffer vessel between the heat pump and heating distribution system to maximise the efficiency of the system. This is achieved by using the volume contained within the heating system itself as the buffer vessel. This means approximately 25% of the under-floor zones or radiators should remain hydraulically open, i.e. no control valves fitted. These areas should provide a minimum load on the heat pump to avoid short cycling. The areas that are left 'open' should be areas where close temperature control is not required i.e. hallways, bathrooms, etc.

For buildings where 'open' zones are not desired, Kensa would recommend the use of a two connection buffer vessel or volume tank as this is the most efficient type of a buffer vessel and avoids the drop in efficiency associated with four connection buffer vessels.

### 2.1 Equipment delivery and handling.

#### Factory shipment

Prior to shipment, the Buffer Vessel unit is tested, calibrated and inspected to ensure proper operation.

#### Receipt of shipment

Each pallet should be inspected at the time of delivery for possible external damage. Any visible damage should be recorded immediately on the carrier's copy of the delivery slip.

Each pallet should be unpacked carefully and its contents checked for damage.

If it is found that some items have been damaged or are missing, notify the manufacturer immediately and provide full details. In addition, damage must be reported to the carrier with a request for their on-site inspection of the damaged item and its shipping pallet.

## 2.2 Buffer Vessel Dimensions and Arrangement

<b>Tappings</b>	4 x 28mm BSP Male Above 150 litres 4 x 2" BSP
<b>Material</b>	Duplex Stainless Steel Except * Mild Steel
<b>Max Operating Pressure and Temperature</b>	3 Bar—95°C
<b>Hydraulic Test Pressure</b>	9 Bar
<b>Insulation</b>	Polyurethane Foam Injection
<b>Insulation 50 &amp; 100 Litre Tank</b>	Rigid Polyurethane and Mineral Wool
<b>Thermostat Probe Pocket</b>	Fitted to cylinders, 1/2" Boss on 100 litre tank
<b>Air Vent</b>	3/4" BSP tapping—cylinders 1/2" Vent (100 litre Tank)

Model	95-045A	95-046A	95-047A
<b>Volume (l)</b>	80	150	200
<b>Weight Full (kg)</b>	95	170	225
<b>Heat Loss kWh/24hrs@50°C</b>	38	55	69
<b>Immersion Heaters</b>	1 x 3kW	1 x 3kW	1 x 3kW
<b>Dimension A</b>	545	545	545
<b>Dimension B</b>	300	335	335
<b>Dimension C</b>	410	845	1150
<b>Dimension D</b>	651	1081	1399
<b>Energy Class</b>	B	B	C

**Note:** Although the buffer vessel is provided with 4 x 28mm BSP connections up to 150 litres and 4 x 2" for larger sizes, only 2 connections should be used to

**Note:** Although the buffer vessel is provided with an immersion heater this should not be electrically connected unless approved by Kensa Energy. The use of an immersion will reduce the efficiency of the system and increase carbon emissions.

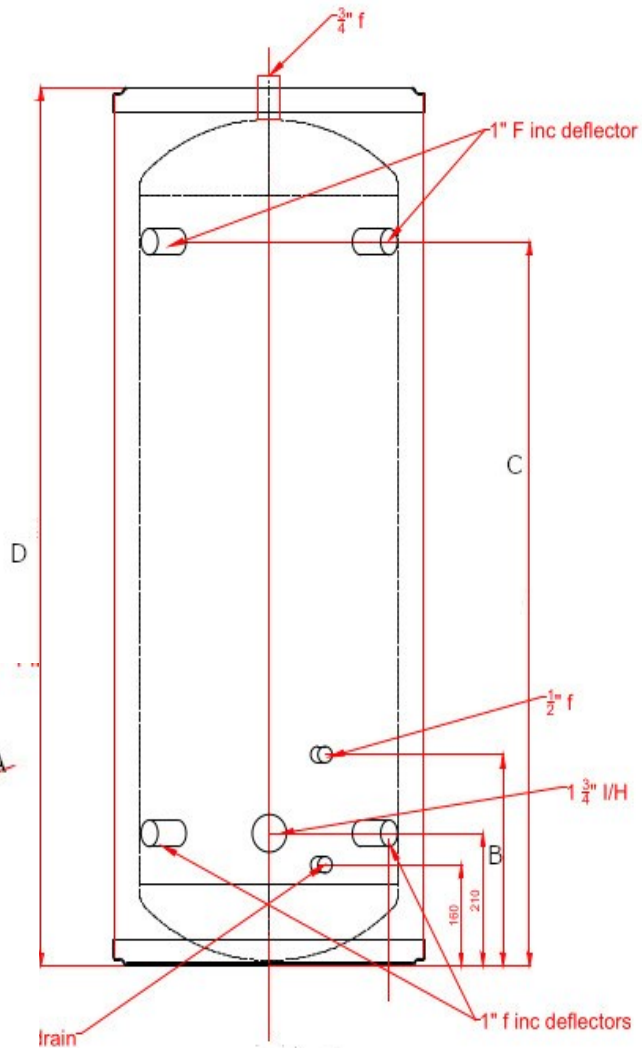
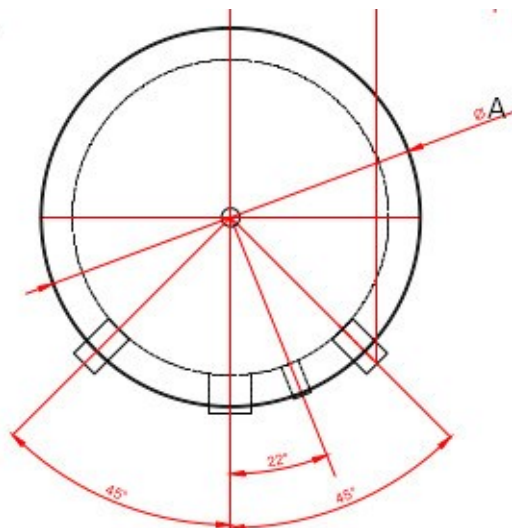

**Note:** An air vent should be fitted to the top 3/4" BSP connection to remove air from the system. It can be of the automatic or manual type.

Kensa Model	95-011A
Advance Appliance Model	BFS100
Volume (l)	100*
Weight Full (kg)	145
Heat Loss kWh/24hrs@50°C	2.05
Immersion Heaters	Can be ordered separately

**Please note: the 100 litre buffer vessel does not include an immersion heater as standard. This can be ordered separately if required.**

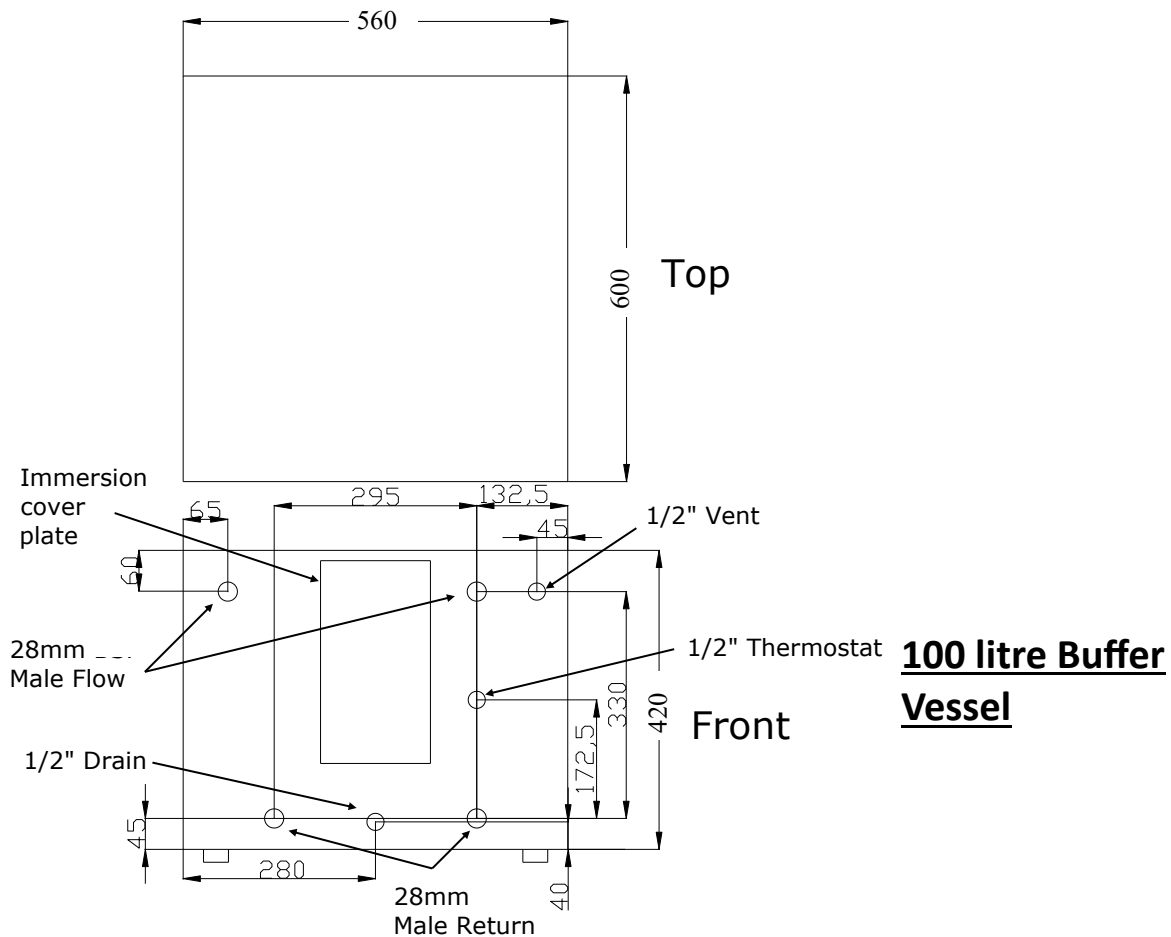

**Note:** Although the buffer vessel is provided with a 3kW immersion heater this should not be electrically connected unless approved by Kensa Heat Pumps. The use of an immersion heater will reduce the efficiency of the system and increase carbon emissions.

**Note:** Although 4 tappings are provided only 2 should be connected via a t-piece to the flow and return to maintain the heat pump efficiency.

## 2.3 General Specification

Tappings	4 x 28mm Male (80, 100 & 150L) 4 x 2" Male (for larger sizes)	
Material	Inner Container & Connections	Duplex Stainless Steel Except * Mild Steel (100litre)
	Outer Casing	Plastisol Mild Steel (100litre)
	Insulation	Polyurethane and mineral wool
Max Operating Pressure and Temperature	3 Bar—95°C 2.5 Bar—95°C—50 & 100 litre tanks	
Hydraulic Test Pressure	9 Bar 3.5 Bar—50 & 100 litre tanks	
Insulation	Polyurethane Foam Injection	
Insulation 50 & 100 Litre Tank	Rigid Polyurethane and Mineral Wool	
Thermostat Probe Pocket	Fitted to cylinders, 1/2" BSP on 100 litre tank	
Air Vent	3/4" BSP tapping—cylinders 1/2" tapping fitted on 100 litre Tank	
Shell and Domes to be designed generally in accordance with BS5500		

## 3.0. Typical Schematics

### 3.1 Twin Coil Cylinder with GSHP (Space Heating and DHW Production)

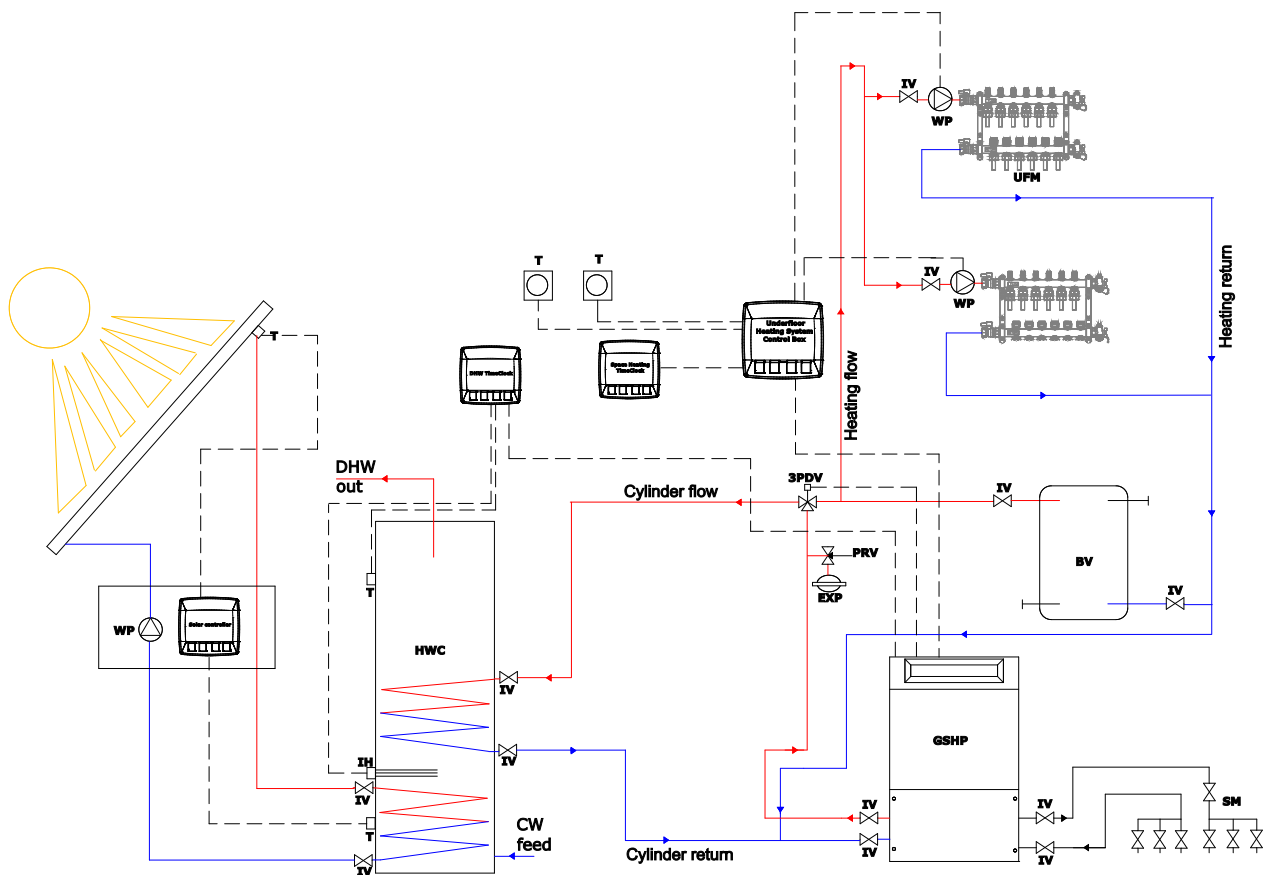

#### Abbreviations

3PDV	- 3 port diverting valve
BV	- Buffer Vessel
DHW	- Domestic Hot Water
CW	- Cold Water
EXP	- Expansion vessel
GSHP	- Ground source heat pump
IH	- Immersion heater
IV	- Isolation valve
PRV	- Pressure relief valve
SM	- Slinky manifold
T	- Thermostat
UFM	- Under-floor manifold
WP	- Water pump

If full control of all heating zones is required the Buffer Vessel (BV) can be fitted (as shown) to reduce short cycling of the heat pump. If 25% of the under-floor zones and radiators are left open this is not normally required.

**Please note:-** The above drawing is a schematic only and additional valves and fittings maybe required.

**Please note:-** Running the GSHP to produce DHW with off-peak tariffs might result in the GSHP needing to operate during peak electricity periods for space heating with higher associated running costs.



### 3.2 Buffer Vessel Installation with the Shoebox Heat Pump

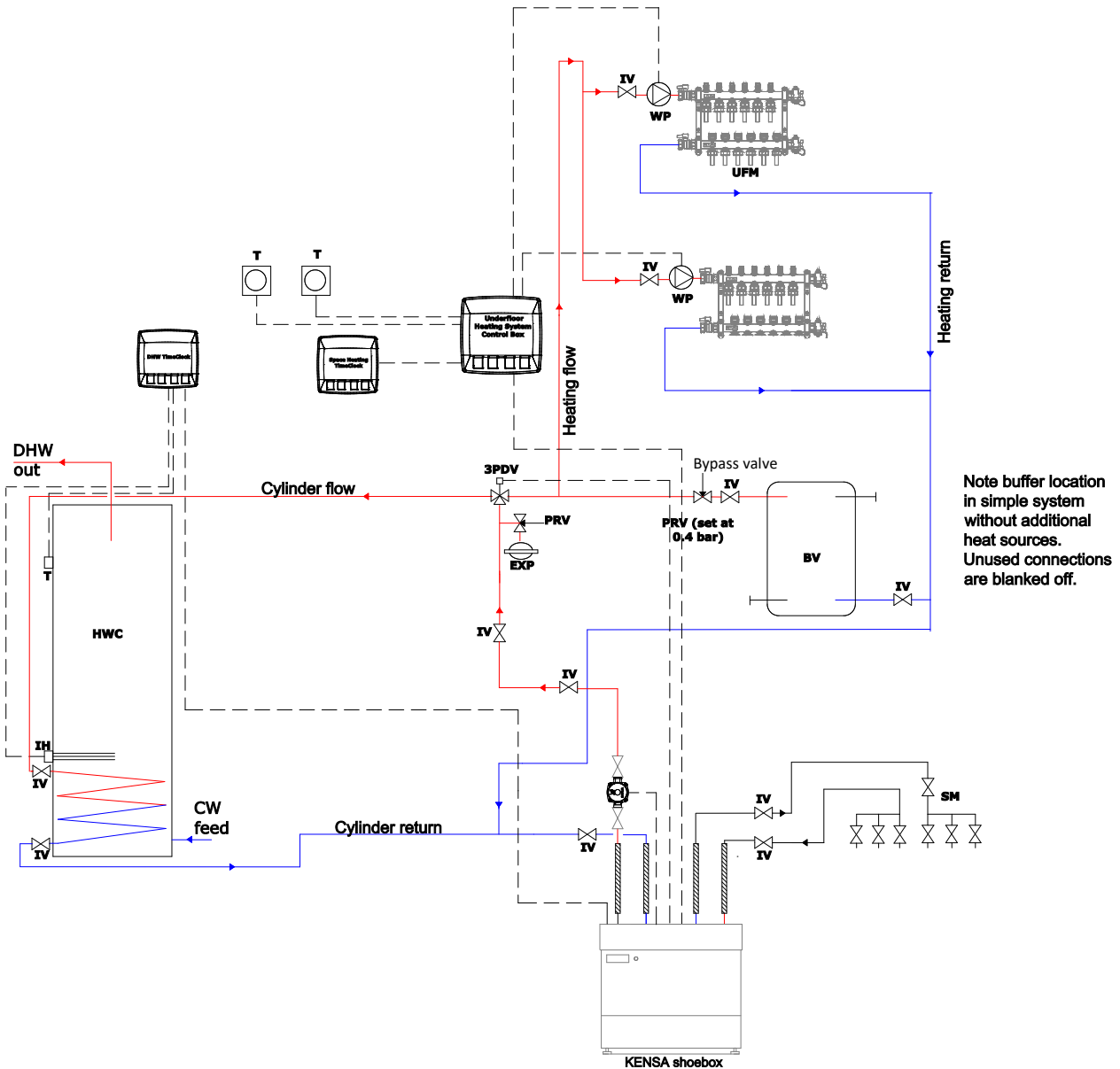

**Shoebox—DHW with under-floor and a buffer vessel**

If close temperature control of all heating zones is required, it is recommended that a buffer vessel is fitted.

The above schematic shows how a buffer vessel can be incorporated into the shoebox installation without the need of a second water pump.

The buffer vessel allows all radiators or under-floor zones to be fully controlled and prevents the shoebox from short cycling, hence removing the need for 'open' zones.

The buffer vessel is connected to a bypass valve which is set at 0.4 bar. As the heating zones throttle down due to the heating requirement being satisfied, the pressure in the heating circuit increases. Once this pressure increases above 0.4 bar, the bypass valve opens, diverting the flow through the buffer vessel maintaining a load on the heat pump and avoiding it from short cycling.

## 4.0 Installation

Please read this leaflet carefully before installation of the product. You should be competent to install the unvented system as defined by the regulations. Please pay special attention to maintenance and service.

Please keep the unit packaged until you are ready to commence installation. The unit should be stored vertically in a dry area, and all safety components kept in the box.

Install in an area that will be accessible in the future. When first fixing take into account that the connections and controls will be front facing to facilitate access.

If using push fit connections i.e. Speedfit attach a piece of copper pipe initially to the vessel stainless steel connection via means of a compression fitting. The push fit connection then can be attached to this. Failure to do this may well cause any push fit connected directly onto the vessel to leak.

Mount the unit vertically on a flat even surface.

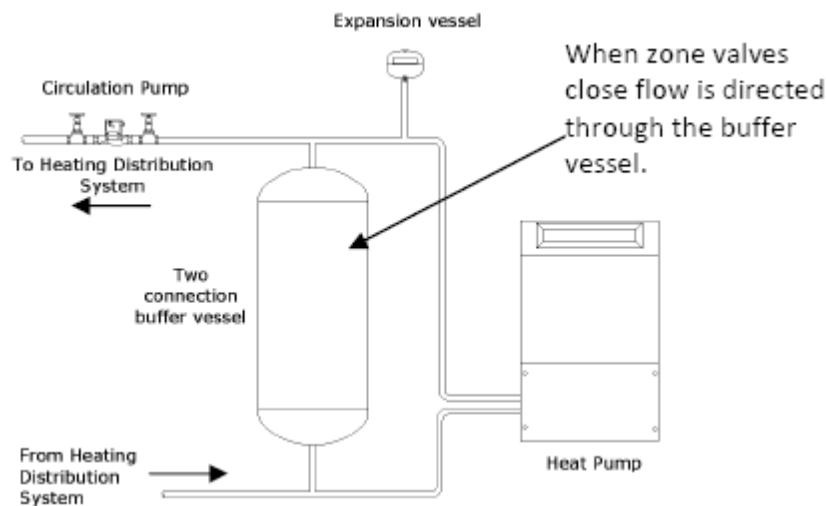

**Please note:- If used in conjunction with the Shoebox heat pump the circulation pump is required to be fitted before the buffer vessel and a bypass valve fitted on the buffer vessel inlet (See section 3.2)**

**Check that the floor will support the unit when it is full of water. See page 5 for weights.**

The unit has a maximum working pressure of 6 bar.

Good system design should take this into consideration & pipe sizing should be in line with current good practice.

## 4.1 Electrical Connections

Although fitted with immersion heaters, Kensa advise that these should not be electrically wired and connected unless approved by Kensa Heat Pumps.

The immersion heater should only be used as a back up in very cold weather as use of the immersion heater will result in higher running costs and higher carbon emissions.

To reduce the effect on cost, if the immersion heater is used then this should be via an off-peak tariff such as economy 7 or economy 10 tariffs.

Immersion heaters are rated 3kw at 240v (2.76kw at 230v), incolloy elements, with a thermal energy cut-out, and must be connected via double pole switches with a 3mm contact gap separation. Appropriate wiring for the electrical load must be used.

Do not switch on until the unit is full of water.

Do not fit an immersion heater without a high limit thermostat. Immersion heaters supplied are designed for domestic use only, either utilising low tariff electricity and occasional boost or for switched periods during the day.

- Units must be earth bonded.
- Immersion heaters must meet BS EN 60730-2-1.
- Fuse rating for 6kw loading is 25 amps, for 3kw models fuse rating is 13 amps.

## 5.0 Commissioning

Before filling, check expansion vessel charge is at 3.0 bar.

1. Open the main supply to the unit.
2. Flush the unit through until all air is expelled, (a vent should be fitted to the top of the unit to facilitate this).
3. Ensure inhibitor is added to the system as required
4. The system is now full of water. Check for any leaks on pipe-work or joints or components such as immersion heaters etc. It is the installers responsibility to check all fittings, including those that are fitted to the unit.
5. Switch on power and heat up via heat pump.
6. Your system should now be ready for use.

## 6.0 Warranty

Advance Appliances guarantees the shell of the stainless steel units for 25 years. The compact mild steel units are guaranteed for 2 years. The component parts are guaranteed for 2 years from date of purchase.

The following information is important – without it your guarantee may be invalid

1. Keep proof of purchase
2. Ensure that installation has been carried out correctly by appropriately approved/competent personnel following relevant Code of Practice.
3. Installation must be in an appropriate location and use is restricted to central heating systems with the appropriate levels of inhibitor added. . Private water supplies are excluded.

Please note that the extended guarantee is not transferable, and rests with the original householder. The above does not affect your statutory rights.

Every effort has been made to ensure that this information is correct. Regulations may change and installers must adopt best current practice.

Advance Appliances/Kensa reserve the right to alter or improve components or specification without notice.