

High Temperature Twin Compressor Compact Heat Pump

Installation and Commissioning Manual



Contents Page

Section	Description	Page
1.....	Introduction	4
2.....	Safety Information	5
2.1.....	Access	5
2.2.....	Lighting	5
2.3.....	Tools and consumables	5
2.4.....	Handling	5
2.5.....	Residual hazards	5
2.6.....	Freezing	5
2.7.....	Disposal/decommissioning	5
3.....	General product information	6
3.1.....	Equipment delivery and handling	6
3.2.....	Kensa Compact technical data	7
4.....	Installation.....	8
4.1.....	The Golden Rules of installing a heat pump	8
4.2	Underfloor heating schematics	8
4.2.1.....	Underfloor with a single manifold. Space heating only	9
4.2.2.....	Underfloor with multiple manifolds. Space heating only	9
4.3.....	Radiators. Space heating only	10
4.4.....	Domestic Hot Water - Schematic	10
4.4.1.....	Type of DHW tank	11
4.4.2.....	DHW tank size	11
4.4.3.....	Immersion heater	11
4.4.4.....	Three Port Diverting Valve	11
4.4.5.....	Tank Thermostat	11
4.4.6.....	DHW Timeclock	11
4.4.7.....	Secondary Returns.....	11
4.5.....	Mechanical Installation	14
4.5.1.....	Locating the Heat Pump	14
4.5.2.....	Recommended Clearances	14
4.5.3.....	Installation of the heat pump	15
4.5.4.....	Meter Installations.....	17
4.5.4.1.....	Meter ready installations.....	17
4.6.....	Electrical Installation	20
4.6.1.....	Single Phase	21
4.6.1.1.....	Single Underfloor Control Unit	21
4.6.1.2	Multiple Underfloor Control Units	22
4.6.1.3.....	Radiator with Thermostat	22

Contents Page

Section	Description	Page
4.6.2.....	DHW time clock and 3 way diverting valve wiring	23
4.6.3.....	Weather Compensation (Optional)	24
5.....	Commissioning	27
5.1.....	Purging the slinkies of air	27
5.1.1.....	Purging procedure for multiple slinkies	27
5.1.2.....	Adding antifreeze for multiple slinkies	29
5.1.3.....	Pressurizing the system	30
5.1.3.1.....	Pressure Testing in accordance to BS805 Section 11.3.3.4	30
5.1.4.....	Testing of antifreeze concentration	32
5.1.5.....	Heating distribution and load side purging	33
5.1.6.....	Reassembling the heat pump	33
5.2.....	Heat pump operation	34
5.3.....	Turning the heat pump on for the first time	34
5.4.....	Altering the flow temperature from the heat pump	35
5.4.1.....	To read flow temperatures and refrigerant pressures	35
5.4.2.....	To change the heat pump return flow temperatures	35
6.....	Fault finding	38
7.....	Warranty.....	39
7.1.....	Terms and Conditions.....	39
7.1.1.....	Persons covered by the Warranty.....	39
7.1.2.....	Validity period of the Warranty.....	39
7.1.3.....	Scope.....	39
7.1.4.....	General exceptions	39
7.1.5.....	Care of Duty	40
7.1.6.....	In the event of Damage	40
7.1.7.....	Replacement Parts.....	40
8.....	Heat pump settings sheet	42

1. Introduction—a message from the CEO



[Kensa Heat Pumps](#) has been manufacturing ground source heat pumps since 1999. In the early days, it was difficult to find contractors willing to consider the technology. As a consequence, Kensa made considerable efforts to simplify the installation process to allow any competent plumber to perform the work. The company is now reaping its rewards as heat pumps become mainstream heating appliances.

The purpose of this manual is to guide you through the installation process. It is expected that all the required information has been provided to allow you to connect the heat pump. Critical instructions, aimed at ensuring you do not experience any difficulties, are highlighted on the 'Golden Rules' in the installation section.

Please note you will need to speak to the Technical Support Team on 01392 367080 to receive the 'online commissioning' service, offered free-of-charge. Opening hours are 8.00am to 5.00pm .

Finally, please feel free to contact Kensa should you have any questions, wish to consider ground source heat pumps for any future projects or even just to share your experiences of using a ground source heat pump with us.

Simon Lomax
CEO
Kensa Heat Pumps Ltd

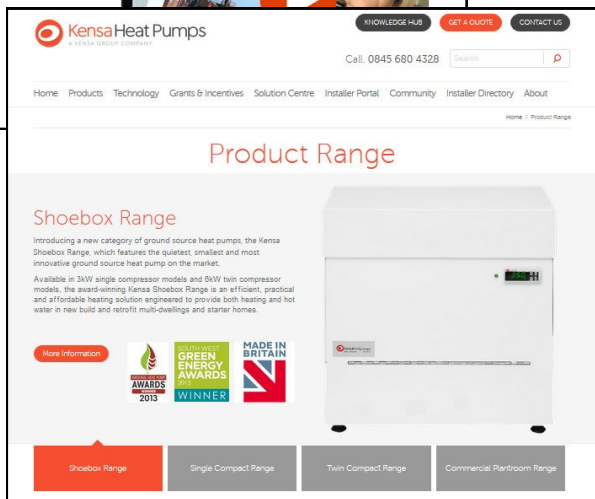
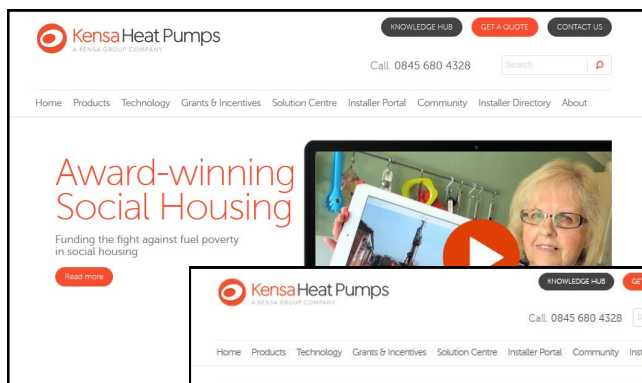

For further information on ground source heat pumps and their application, please refer to www.kensaheatpumps.com

2. Safety information

Safe operation of this unit can only be guaranteed if it is properly installed and commissioned in compliance with the manufacturer's requirements. General installation and safety instructions for pipeline and plant construction, as well as the proper use of tools and safety equipment must also be complied with.

Manufacturer:-
Kensa Heat Pumps
Mount Wellington
Chacewater
Truro
Cornwall
TR4 8RJ
Tel 01872 862140
www.kensaheatpumps.com

The product is designed and constructed to withstand the forces encountered during normal use. Use of the product for any other purpose, or failure to install the product in accordance with these Installation and Commissioning Instructions, could damage the product, will invalidate the warranty, and may cause injury or fatality to personnel.

2.1 Access

Ensure safe access before attempting to work on the product. Arrange suitable lifting gear if required.

2.2 Lighting

Ensure adequate lighting, particularly where detailed or intricate work is required.

2.3 Tools and consumables

Before starting work ensure that you have suitable tools and / or consumables available.

2.4 Handling

Manual handling of large and /or heavy products may present a risk of injury. Lifting, pushing, pulling, carrying or supporting a load by bodily force can cause injury particularly to the back. You are advised to assess the risks taking into account the task, the individual, the load and the working environment and use the appropriate handling method depending on the circumstances of the work being done.

2.5 Residual hazards

Many products are not self-draining. Take due care when dismantling or removing the product from an installation.

2.6 Freezing

Provision must be made to protect products which are not self-draining against frost damage in environments where they may be exposed to temperatures below freezing point.

2.7 Disposal/Decommissioning

Kensa offer a life time decommissioning service for this product. This is available on a return to base basis (carriage at users' cost).

Disposal of any antifreeze water mix should follow the disposal instructions as laid out on the COSH Safety Data Sheet available on request.

3. General Product Information

This manual explains how to install and commission a Kensa ground source heat pump.

The [Kensa Compact Twin Compressor Heat Pump](#) is designed to provide a low cost renewable heat source for a buildings heating system. In addition, and if required, the Kensa Compact can also provide domestic hot water. Heat pumps can provide lower running costs and will generate significantly lower carbon emissions compared with traditional fossil fuels.

The Kensa Compact Twin Compressor Heat Pump is designed for straightforward installation and requires no specialist training to install. However the installation must conform to all relevant construction and electrical codes and comply with the requirements of the Microgeneration Certification Scheme (MCS) MIS3005 'Requirements for Contractors undertaking the Supply, Design, Installation, Set to Work Commissioning and Handover of Microgeneration Heat Pump Systems'

3.1 Equipment delivery and handling.

Factory shipment

Prior to shipment, the Kensa Compact Twin Compressor Heat Pump is tested, calibrated and inspected to ensure proper operation.

Receipt of shipment

Each pallet should be inspected at the time of delivery for possible external damage. Any visible damage should be recorded immediately on the carrier's copy of the delivery slip.

Each pallet should be unpacked carefully and its contents checked for damage.

If it is found that some items have been damaged or are missing, notify Kensa immediately and provide full details. In addition, damage must be reported to the carrier with a request for their on-site inspection of the damaged item and its shipping pallet.

Storage

If a Kensa Heat Pump is to be stored prior to installation, the environmental storage conditions should be at a temperature between 0°C and 70°C (32°F and 158°F), and between 10% and 80% relative humidity (non-condensing).

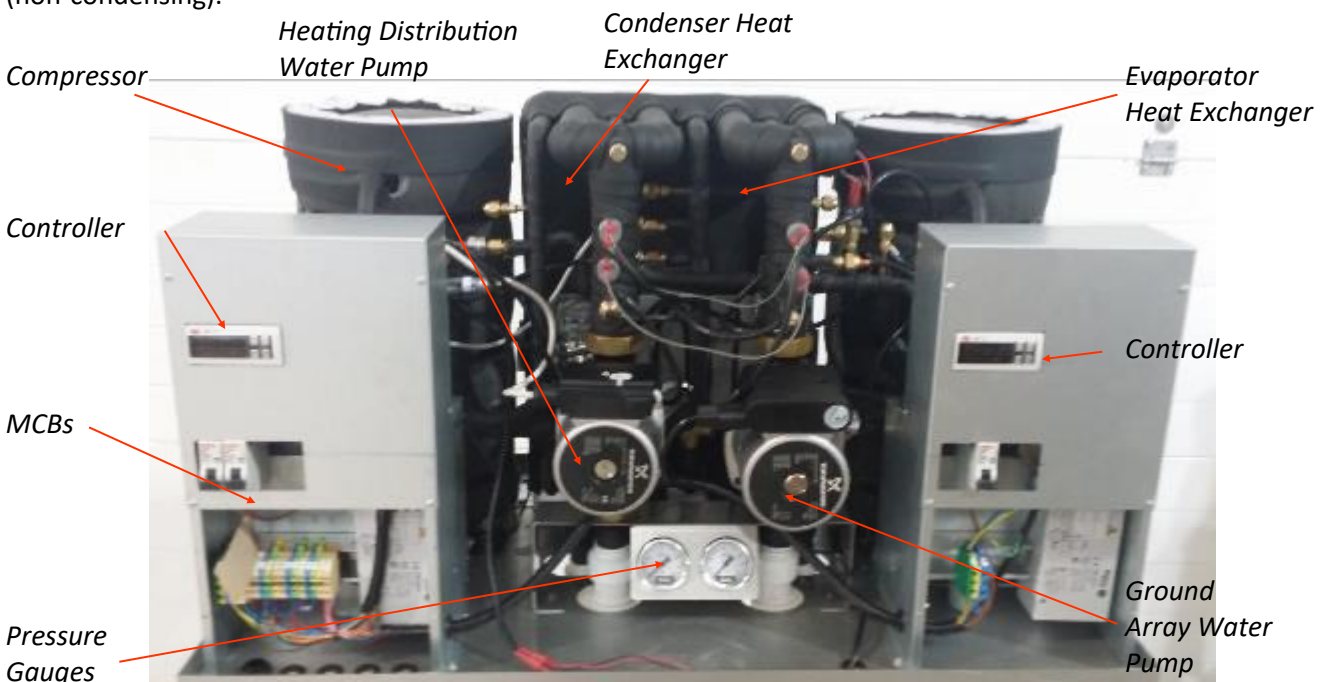

Fig 1. The internals of a heat pump

3.2 Kensa High Temperature Compact Technical Details—Twin Compressor										
Nominal Thermal Output	Power supply rating	Max running Current	Typical running current	Typical starting current	Power input*	Nominal dry weight	Compressors	Dimensions	Connection size	Recommended minimum heat transfer area in DHW tank (not supplied)
kW	Amps	Amps	Amps	Amps	kW	Kg	Number	HxWxD	mm OD	m ²
Single Phase—230 Volts AC 50 Hz										
12	50	43	24 (30)	42	3.4(5.8)	165	Twin	900x900x570	28	1.2
17	50	48	23 (28)	42	4.7(7.2)	167	Twin	900x900x570	50	1.7

The figures above are based on a rating to BS EN14511, 0 deg C from the ground, 35 deg C flow to under-floor. The figures in parentheses are values obtained to BS EN14511, 0 deg C from the ground, 65 deg C to the heating distribution system.

*Includes the power consumption of both inbuilt water pumps.

For clarification of starting currents and details on how these figures are calculated please contact Kensa.

4. Installation

Note: Before actioning any installation observe the 'Safety information' in Section 1.

It is essential that the following installation guidelines are followed carefully.

The installation must conform to all relevant construction and electrical codes and comply with the requirements of the Microgeneration Certification Scheme (MCS) MIS3005 'Requirements for Contractors undertaking the Supply, Design, Installation, Set to Work Commissioning and Handover of Microgeneration Heat Pump Systems'

Any electrical work required to install or maintain this appliance should be carried out by a suitably qualified electrician in accordance with current IEE regulations.

Any plumbing work should be carried out to local water authority and WRC regulations.

4.1 The Golden Rules of Installing a Heat Pump

1. A 'C' Type MCB should be used for the heat pumps power supply.
2. Connect the heat pump using only plastic pipe.
3. Use the Kensa recommended purge pump for purging the ground arrays and heat pump.
4. On the under-floor heating manifold(s), remove the thermal mixing valve(s) if fitted.
5. On the under-floor heating manifold(s), don't fit electric actuators to more than 75% of the zones.
6. Remove the chrome screws on the water pumps, and check that both pumps are running, and moving water before turning on the compressor (25 MCB on the unit) (See section 5.3). For pumps model 30/10 (i.e. 16kW and above) there is no chrome screw.
7. Do not install the heat pump adjacent to or beneath bedrooms or noise sensitive areas.
8. Read this manual fully before commencing installation
9. Do not connect the heat pump to a thermal store without consulting Kensa first.
10. An electrical isolation switch should be fitted close to the heat pump.
11. Existing heating systems should be power flushed and inhibitors should be added.

4.2 Under-floor Heating Schematics

The following section includes typical schematics of how a heat pump can be connected. Only the load side is shown i.e. the heating distribution system. It is important to note that the schematics are only general arrangements and hence do not illustrate all required valves or fittings.

On the [under-floor heating](#) manifold(s) remove any thermal mixing valves, if fitted.

To avoid the heat pump from short cycling, it is important that the under-floor is capable of accepting the minimum load from the heat pump or a buffer vessel is fitted.

The easiest way to do this is simply to have some zones left "open" – i.e. without electric actuators. These zones will still require thermostats so can call for heat when required. In houses, the best zones to chose are en-suite bathrooms, and hallways, neither of which are likely to be overheated.

To avoid short cycling of the heat pump the smallest actuator controlled zone (plus all the open zones on that manifold) should be capable of absorbing the minimum thermal load of the heat pump. This minimum load is approximately 25% for twin compressor heat pumps.

If a fully controlled zone system is required, then a buffer vessel will be required (ideally a two connection tank). This can result in a lower overall efficiency of the system (due to the higher temperatures, pump electricity usage, etc) and hence Kensa would always advise that the 'open zone' method of avoiding short cycling is used.

4.2.1 Under-floor with a single manifold. Space heating only

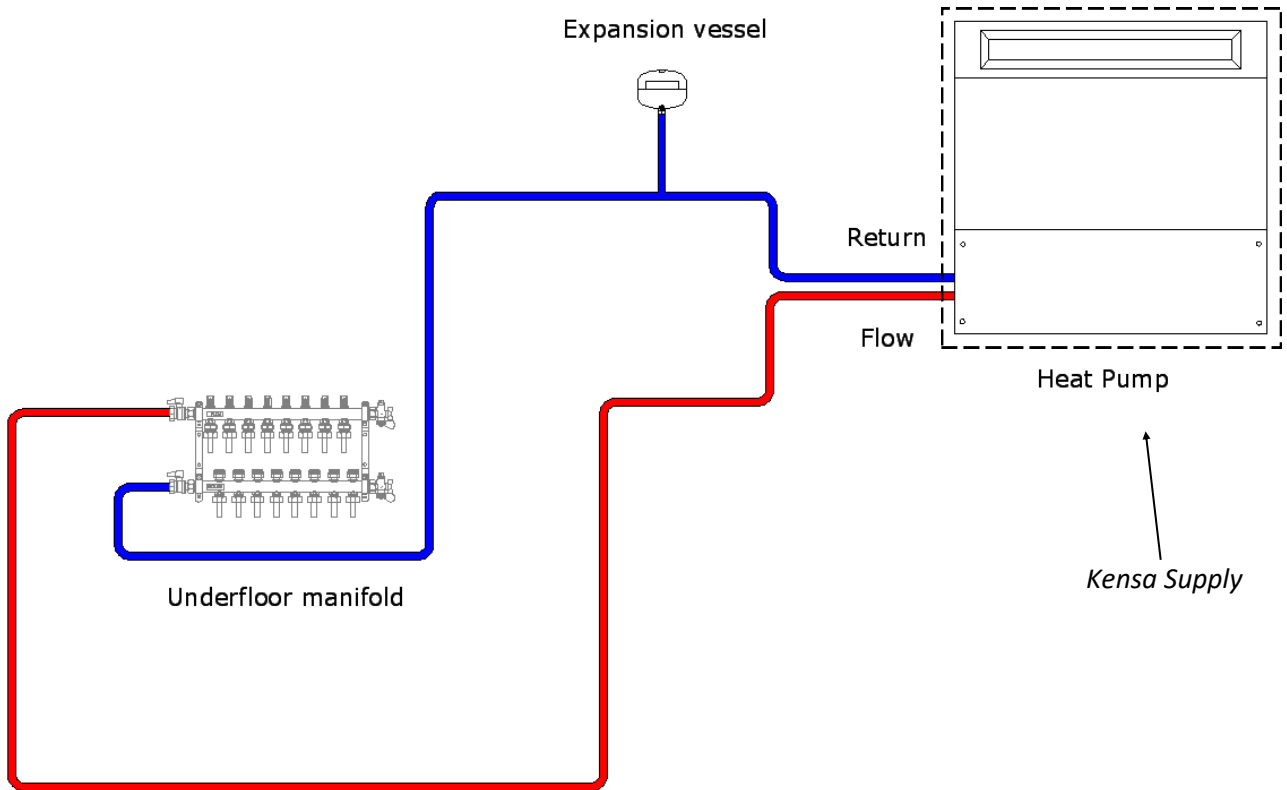

Fig 2 Heat Pump with Under-floor and a Single Manifold Schematic

4.2.2 Under-floor with a multiple manifolds. Space heating only

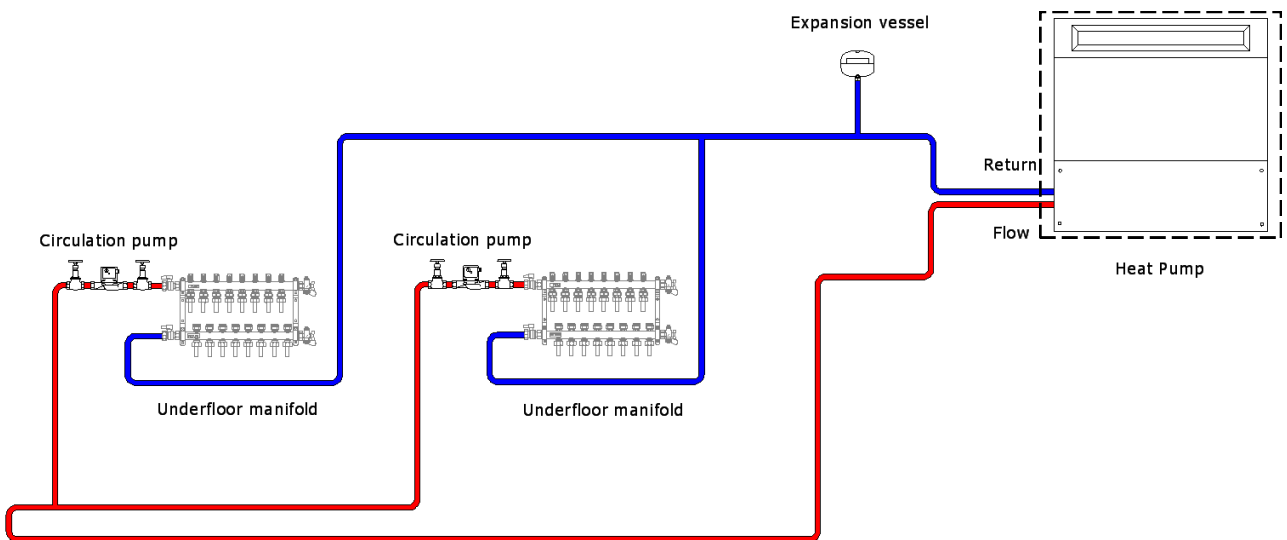

Fig 3 Heat Pump with Under-floor and a Multiple Manifolds Schematic

4.3 Radiators. Space heating only

The following section includes typical schematics of how a heat pump can be connected. Only the load side is shown i.e. the heating distribution system. It is important to note that the schematics are only general arrangements and hence do not illustrate all required valves or fittings. They are only a guide and should not be used as full installation plans.

When operated with [radiators](#) to avoid short circulating problems, one bypass radiator should be left 'open', i.e. any TRV is removed. This radiator can be positioned in areas such as halls or bathrooms.

Kensa would always recommend fitting an expansion vessel on the heating distribution circuit.

Fig 4 Heat Pump with Radiators Schematic

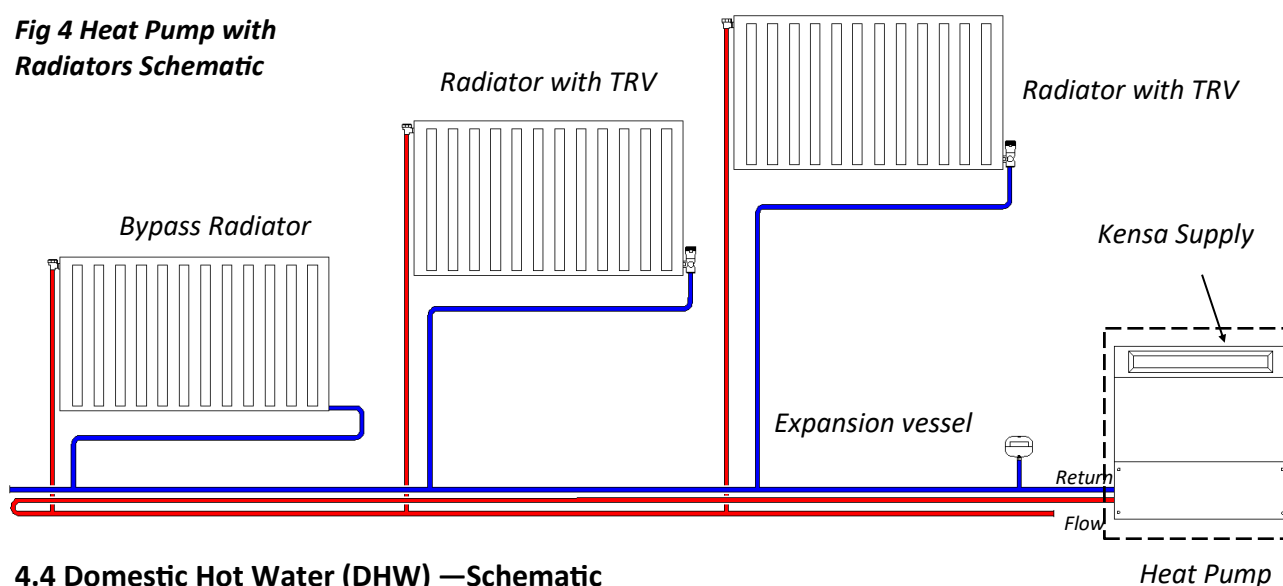

4.4 Domestic Hot Water (DHW) —Schematic

The DHW option needs to be specified at time of ordering.

Warning - when a heat pump is used for heating domestic hot water, it may not get the water hot enough to kill the dangerous Legionella that can breed in hot water cylinders. Alternative arrangements should therefore be made to ensure the cylinder is pasteurised regularly.

Under normal conditions the heat pump will provide heat for the space heating distribution system at its design temperature (typically 35°C for under-floor and 45-50°C for radiators).

When the DHW time clock calls for production of DHW, the three-port valve diverts the flow from the heating distribution circuit into the indirect coil. The temperature of the water from the heat pump is raised to approximately 65°C. The lights to the right of the controllers indicates when DHW production is operational.

When the DHW production time period ends, the three port valve switches back to the under-floor distribution and the temperature drops back to its space heating design temperature. The heat pump then reverts to space heating mode or switches off if no zones are calling for heat. The heat pump will not re-enter into DHW mode until 2 hours has passed. Please contact Kensa if this time period needs to be adjusted .

The maximum DHW temperature that the heat pump can achieve will be approximately 65°C. In summer, it could be higher, due to the warmer ground conditions. If 65°C is required to be guaranteed all year round, it is recommended that an immersion heater is linked to a second channel on the DHW time clock and this is programmed to operate for a period immediately following the DHW production. This means that the majority of the heating load for the DHW is produced at a lower cost using the heat pump, as



opposed to using only the direct immersion heater.

4.4.1 Type of DHW Tank

The larger size the coil within the tank, the better the heat transfer area and hence the better the DHW performance will be. (Refer to table 3.2). Ideally the coil should be a minimum of 0.2 sqm per kW DHW output from the heat pump.

4.4.2 DHW Tank Size

The tank will need to be carefully sized to meet the DHW demand, based on the number of occupants and should have an acceptable recovery rate. Due to the lower DHW temperature achieved by the heat pump, a tank 30% larger than normal is recommended. This is due to the higher demand on the tank, as less cold water is used at the point of use to mix the lower temperature DHW to an acceptable temperature.

4.4.3 Immersion Heater

Although not required by Building Regulations, it is generally advised that to provide legionella protection the tank is raised above 60°C at least once a week. To provide this we would recommend that a 3 kW electric immersion heater is fitted to the bottom of the tank, with its own dedicated 7- day time clock.

4.4.4 Three Port Diverting Valve

If the DHW option is ordered, a 3 port diverting valve ('W' plan) is provided by Kensa and is used to divert the flow when the time clock calls for DHW production from space heating to the DHW tank. The valve's electrical connections are connected to the heat pump's internal wiring. Please note connection 'A' is DHW and 'B' is space heating. Please note the valve should be installed with the motor at any angle vertical to 30° above the horizontal plane .

4.4.5 Tank Thermostat

A tank thermostat is not required but maybe fitted and used as a tank safety stat if wired in series with the time clock. This should be set at not less than 65°C.

4.4.6 DHW time clock

A 24 hour time clock is required to control the production of DHW and is connected to the heat pump's internal wiring. (See section 4.6.3). This time clock is supplied by others.

4.4.7 Secondary Returns

In long DHW pipe runs, to avoid excessive water draw off before the water is up to temperature at the point of usage, it is common to install cylinders with a secondary return. This is not recommended for

systems using heat pumps as it promotes mixing in the tank and a lower flow temperature off the cylinder.

For long pipe runs, to avoid excessive cold water draw offs it is recommend that a flow boiler is used and the pipe is well insulated.

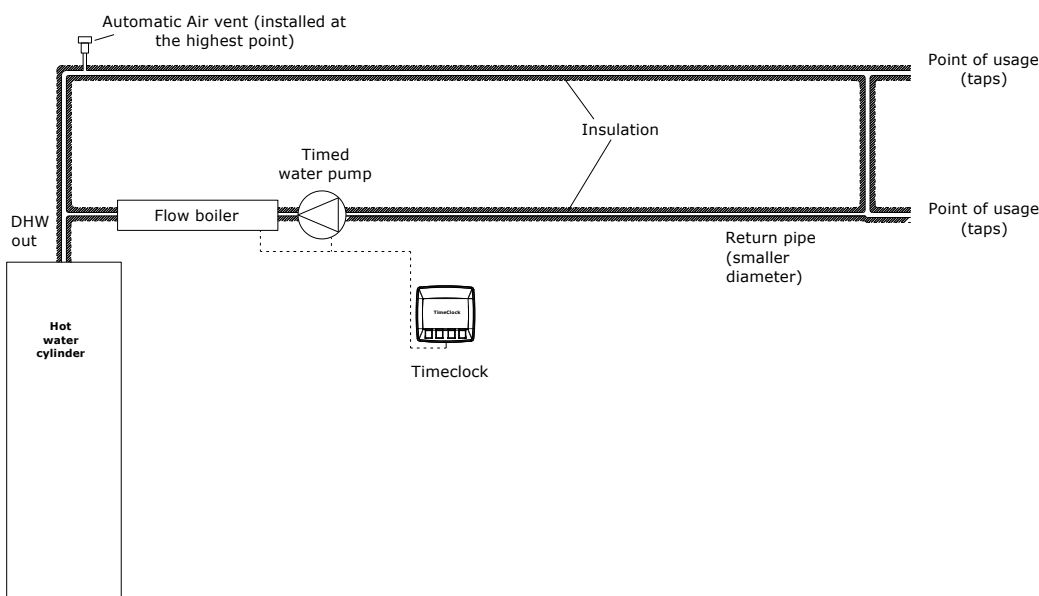

The system uses a return loop, however instead of connecting to the tank it is connected to the tank outlet. A timed water pump is also used and a flow boiler (Willis heater), which makes up any losses to atmosphere from the pipework. The return pipe should also be a smaller diameter than the flow pipe. It is important that an automatic air vent is installed at the highest point of the system.

The operation of the water pump and flow boiler should be timed to a period/s around the time the most hot water is used, i.e. early morning and evening.

If the water pipe is well insulated and the system is timed, the amount of energy this system will use is minimal. It is also possible to use trace heating tape, this removes the additional cost of installation of the secondary return and water pump and the associated running costs of this equipment.

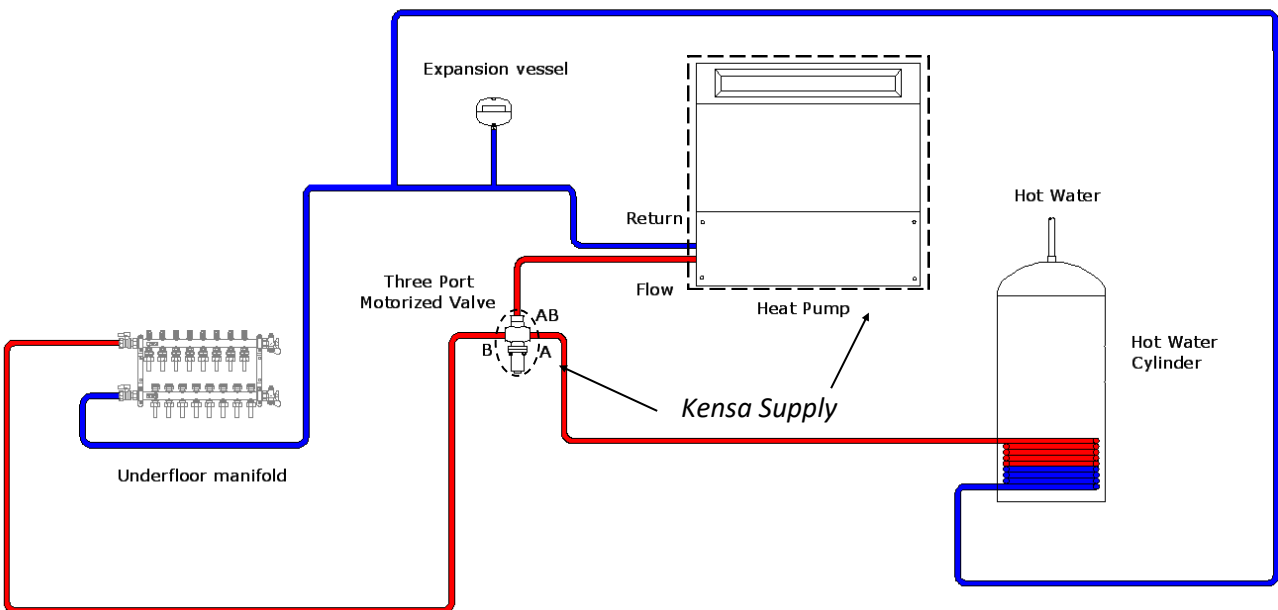

Fig 5 Under-floor with a single manifold and DHW Schematic

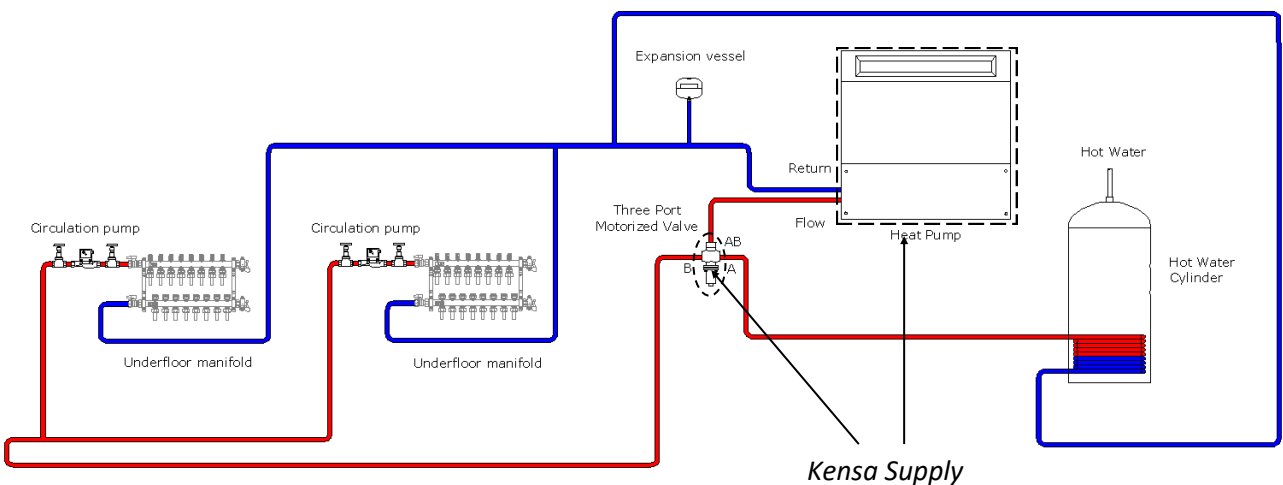
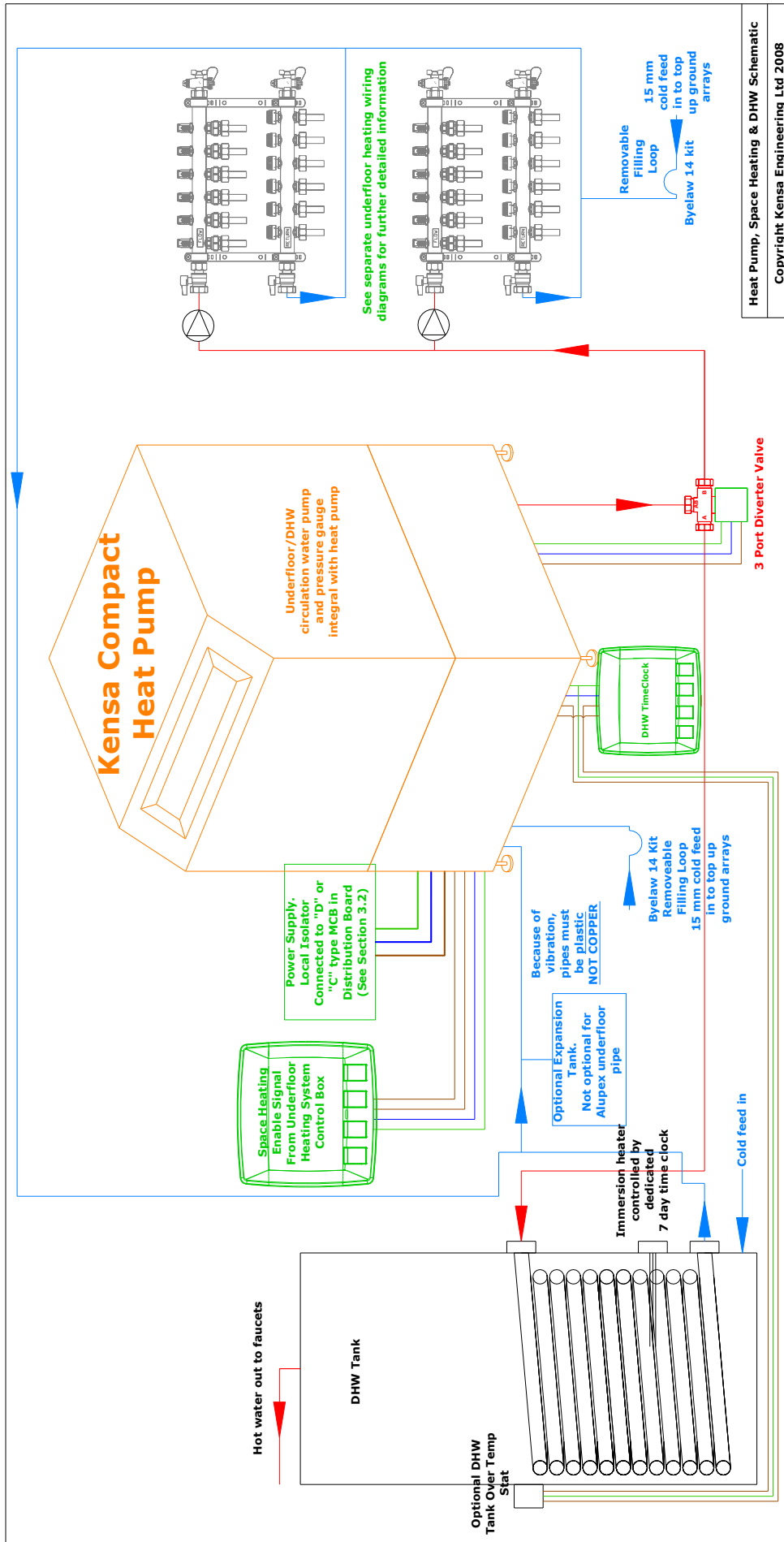

Fig 6 Under-floor with multiple manifolds and DHW Schematic

Note: Additional circulation pumps with multiple manifolds depends on the system design.



Please note the 3 port diverter valve should be installed with the motor at any angle vertical to 30° above the horizontal plane .

Fig 7 Heat Pump with DHW Schematic

4.5 Mechanical Installation

4.5.1 Locating the Heat Pump

Decide on a suitable location for the Heat Pump. This should ideally be in the back of a domestic garage, or a utility room. It should not be placed in any inhabited space or near any noise sensitive areas. The Compact emits limited noise and vibration, and should not be placed adjacent to, or below bedrooms or occupied spaces. Take into account the “Recommended Clearances” when finalising the location.

Check the appliance for transport damage. Under no circumstances should a damaged appliance be operated or installed.

Position the appliance on a firm, level and substantial concrete base that will absorb vibration well away from any occupied rooms. Ensure that the appliance does not stand on the electrical supply cable. If the supply cable is damaged, it must be replaced. Ensure all pipes and wires are adequately supported where necessary, pipes are properly insulated and concentrations of inhibitor (where added) are correct. The appliance and any metal pipes should be properly earthed.

A water treatment device should be provided in hard water areas.

If the heat pump is being located in a damp environment, the ground array water pump should be insulated with a vapour barrier insulation such as Armaflex to avoid excessive condensation.

Do not use the appliance as a shelf.

4.5.2 Recommend clearances

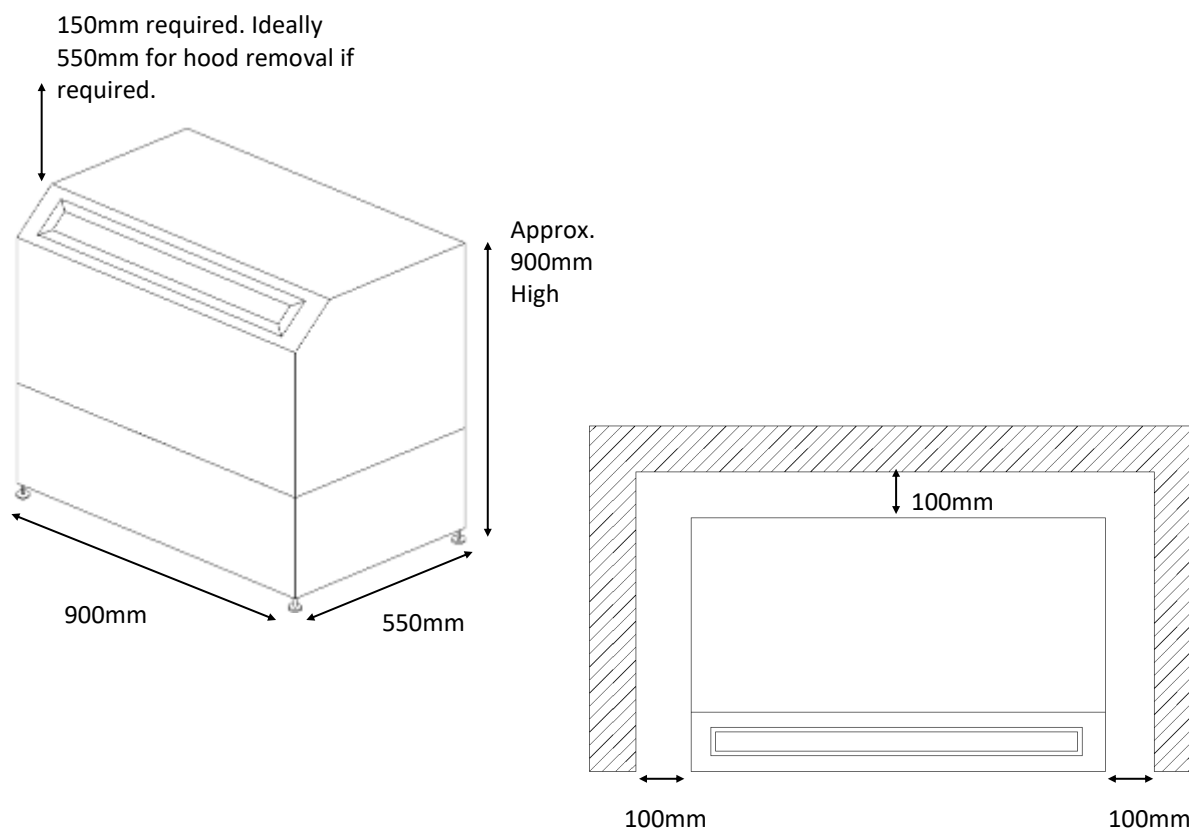

Fig 8 Heat Pump clearances

4.5.3 Installation of the heat pump

Ideally the heat pump should be placed next to an external wall allowing easy access to the externally mounted ground array manifold. Any pipes internal to the building must be insulated with vapour barrier insulation such as Armaflex. It is not recommended that the ground array manifold is installed within a building due to condensation and difficulty in lagging the manifold to overcome this.

It is possible to place manifolds in underground chambers, however due to a possible flooding risk and easier access Kensa recommend that the manifold is placed on an external wall.

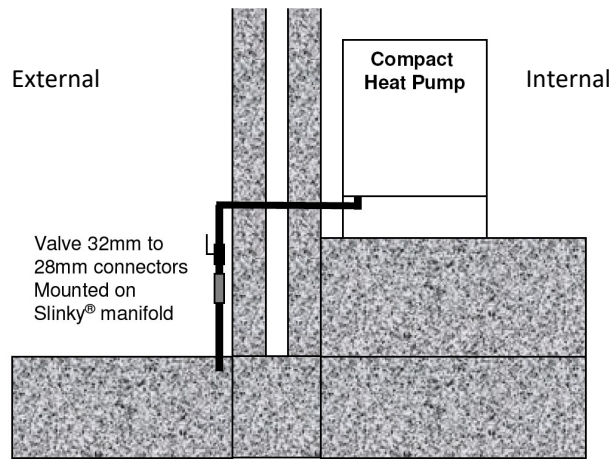

Fig 9 Positioning of Heat Pump and Manifold

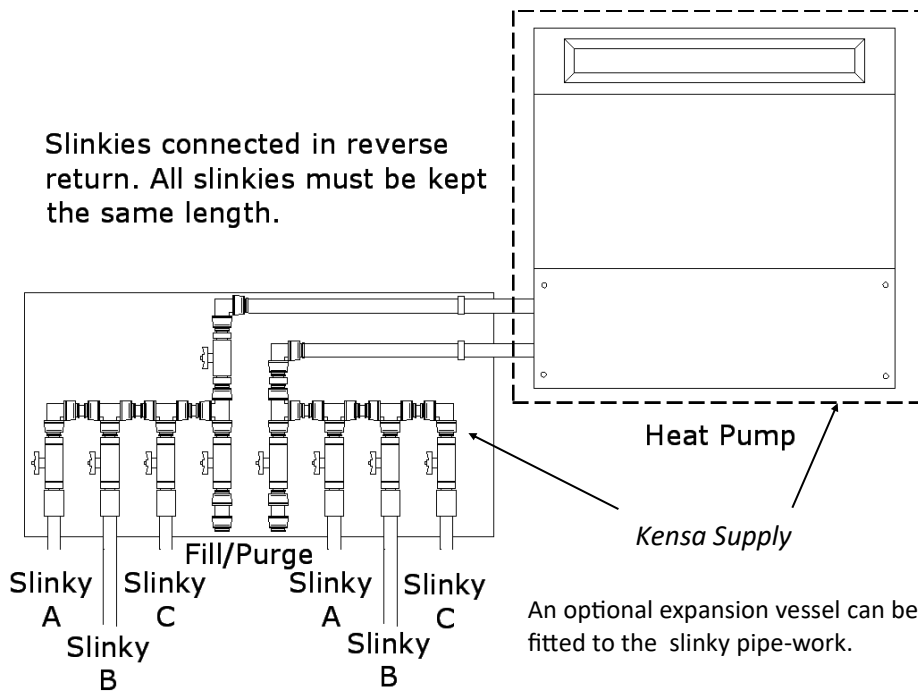
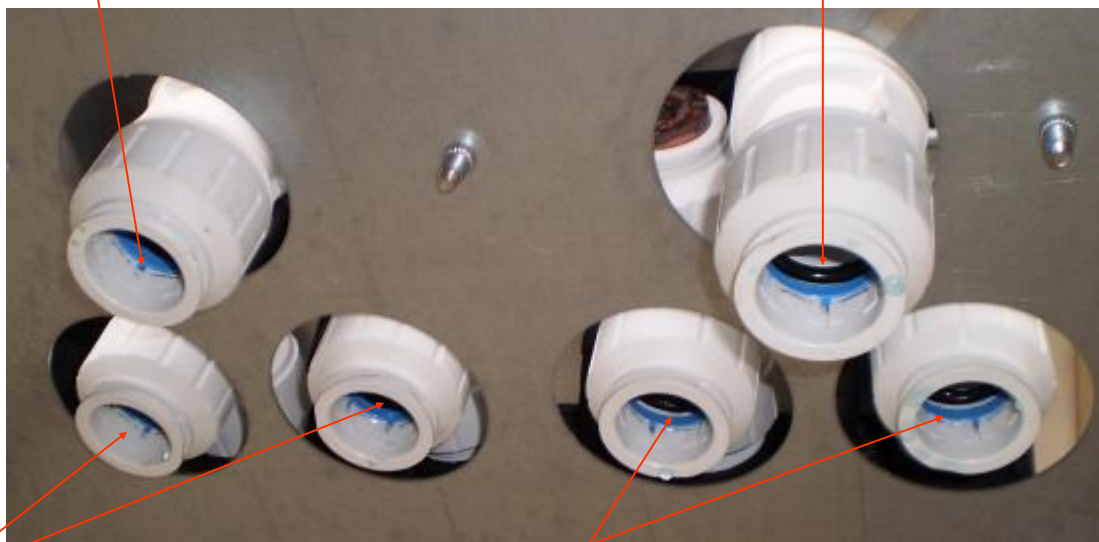

Fig 10 Manifold Slinky connections

- i. Unscrew the 4 x 5mm hex-socket screws, 2 on either side of the front panel. Remove the front panel.
- ii. Remove all three lower closure panels necessary to gain access to the pipe connections, by unscrewing the 4 x hex-socket screws on each panel.
- iii. Position the appliance on a firm, level and substantial concrete base that will absorb vibration and ensure the unit is well away from any occupied rooms.
- iv. Using the adjustable feet, level the unit and tighten the M10 locking nuts on the feet when level.
- v. Ensure the heating distribution system has been thoroughly purged of any debris.
- vi. **Using only plastic flexible pipe such as "Speedfit",** connect the cold feed, ground feed & return pipes from the Slinky manifold (which can be connected either way round, unless flow indicators on the return are present on the slinky manifold), feed & return pipes from the under-floor heating manifold (which must be connected the correct way round), according to the Illustration below. The reason for using flexible pipe is that the heat pump is suspended on anti-vibration mounts, so the connections must also be flexible. Using the stickers provided ensure the flow and return connections are indicated on the manifold. To aid with the connections various pipe connectors are provided, a 'Y' connector (for connection for the heating system return), a 'F' connector (for connection to the ground supply) and a 'L' connector (for the return from the ground).

Flow to heating system from heat pump 28 mm OD

Return from ground to heat pump 28 mm OD. Connected via 'L' connector with a single 50mm Plasson connection termination.



Return from heating system to heat pump. Connected via 'Y' connector 28mm OD Speedfit connection termination.

Supply to ground from heat pump 28 mm OD. Connected via 'F' connector with a single 50mm Plasson connection termination.

Fig 11 Twin Compressor heat pump connections (from the front of the unit.)



Fig 12 'Y' Connector



Fig 13 'F' Connector



Fig 14 'L' Connector

- vii. Thread the power supply and time clock/room thermostat wires from under the Compact into the control box and connect them to the terminals required, (see electrical installation section).
- viii. If required fit the optional weather compensation sensor to a North facing wall, and connect with two-core minimum 0.5mm sq cable (see Section 4.6.4). The use of weather compensation on heat pumps is unlikely to give any significant cost savings and can actually increase the cost of running a heat pump. For this reason, Kensa Heat Pumps are supplied with this function disabled in the software.
- ix. For applications where Domestic Hot Water has been specified a 3 port diverting valve ('W' plan) is provided by Kensa and when the time clock calls for DHW production is used to divert the flow from space heating to an indirect coil in the DHW tank, (See DHW schematic, Section 4.4). The diverting valve should be first connection in the heat pumps flow line, before any under-floor heating manifolds. The valve's electrical connections are connected to the heat pump's internal wiring. (See 4.6.3)
- x. Check and rectify any leaks that may be in the plumbing system.
- xi. The appliance should be left for 12 hours after installation before it is turned on, to allow the refrigerant to settle. The area where the heat pump is installed must be dry and rodent free.

4.5.4 Meter Installations

The government has introduced the [Renewable Heat Incentive \(RHI\)](#) to support renewable heat generation in the domestic sector. The scheme will offer tariff payments for supported technologies which include MCS (or equivalent)-certified solar thermal systems, ground source heat pumps, air source heat pumps and biomass boilers or stoves with back boilers for use in the domestic sector.

It is good practice that RHI installations should be made meter-ready. In addition, in some cases, applicants will require metering for payment in order for their systems to be RHI-compliant, whilst in other cases, applicants could be paid extra for monitoring of system performance.

MCS guidelines make three distinct types of meter installation

Meter-ready– It is good practice that all RHI installations should be meter-ready for BEIS's own metering to be fitted to the site if selected.

Metering for payment- Where a heat pump or biomass boiler is installed alongside certain other heating systems or where the installer is advised that the property is a second home, then the renewable heating system shall be metered in order to receive payment under the RHI.

Metering and Monitoring Service Packages- A Customer may install an optional metering and monitoring service package for either a pellet biomass boiler or a heat pump for which they will receive a financial uplift. The specifications for installation of meters as part of these packages are detailed in this section along with any other requirements in order for the package to be installed in a form that is compliant with the RHI.

For information on Metering for payment and Metering and Monitoring Service Packages it is recommended that the MCS document *MCS Domestic RHI Metering Guidance V1.0* is consulted. The section below covers 'meter ready' installations only.

4.5.4.1 Meter Ready Installations

Some installations incentivised through the RHI will have BEIS's own metering fitted where the metering data may then be used to allow BEIS to evaluate the effectiveness of the policy and data may be shared

with MCS.

BEIS may install meters to monitor the heat output from a renewable heating system, the energy consumed by those same heat sources, and the heat output from any back-up fossil fuel systems. This could require engineers, appointed by BEIS, to install a number of heat meters, electricity meters or other energy meters, depending on the specific heating system and manner of installation. In addition, BEIS will install a number of temperature sensors to develop an understanding of the behaviour of a range of heating systems, for example temperature measurement of space heating flow and domestic hot water flow. The sensor outputs will be connected to a logger that will store all readings and regularly transmit them to a centralized secure data source.

It is good practice that RHI-compliant renewable heating installations should be made meter-ready. MCS installers should:

1) Leave sufficient space for appropriate meters to be fitted in defined locations; Heat pumps

The flow meter and return temperature sensor of the heat meter(s) take up the most space and need to be situated on the return pipe-work between the circulation pump and the distribution system. The required length of straight pipe-work between isolation valves is 20 times the pipe diameter to enable BEIS's chosen metering to be installed on the return pipe-work. The table below shows the length of straight pipe required for a number of standard pipe sizes.

For each location where a heat meter is required, a section of pipe of 175 mm should be left for the heat meter temperature sensor in the flow pipe-work. This should be no more than 2 m from the flow meter.

Pipe Diameter (mm)	Total length of straight pipe-work required in return pipe (mm)	Total length of straight pipe-work required in the flow pipe (mm)
15	300	175
22	440	175
28	560	175
35	700	175
42	840	175

2. Install low pressure-drop isolation valves to avoid the need to drain systems when fitting heat meters;

These should be installed at each point where heat metering is required. Heat metering installed between the isolation valves should be able to record the total heat output from the heating system (excluding individual room heaters and immersion heating, the latter of which will be monitored through electricity sensors). Therefore, if there are several return pipes connected to a renewable heating installation, then each one will need to be heat metered, and each one will need to be fitted with isolation valves with sufficient separation to allow heat meters to be installed.

3. Leave sufficient pipe-work accessible, i.e. not boxed in or under floor boards, to enable meters to be fitted;

Notes on making an installation 'meter ready'

Heat meters that have been used by BEIS in their metering programmes in the past have required a mains electricity connection. Therefore, at the same time as installing isolation valves for the heat meters, installers should consider the placement of an easily-accessible electricity supply to power the heat meters.

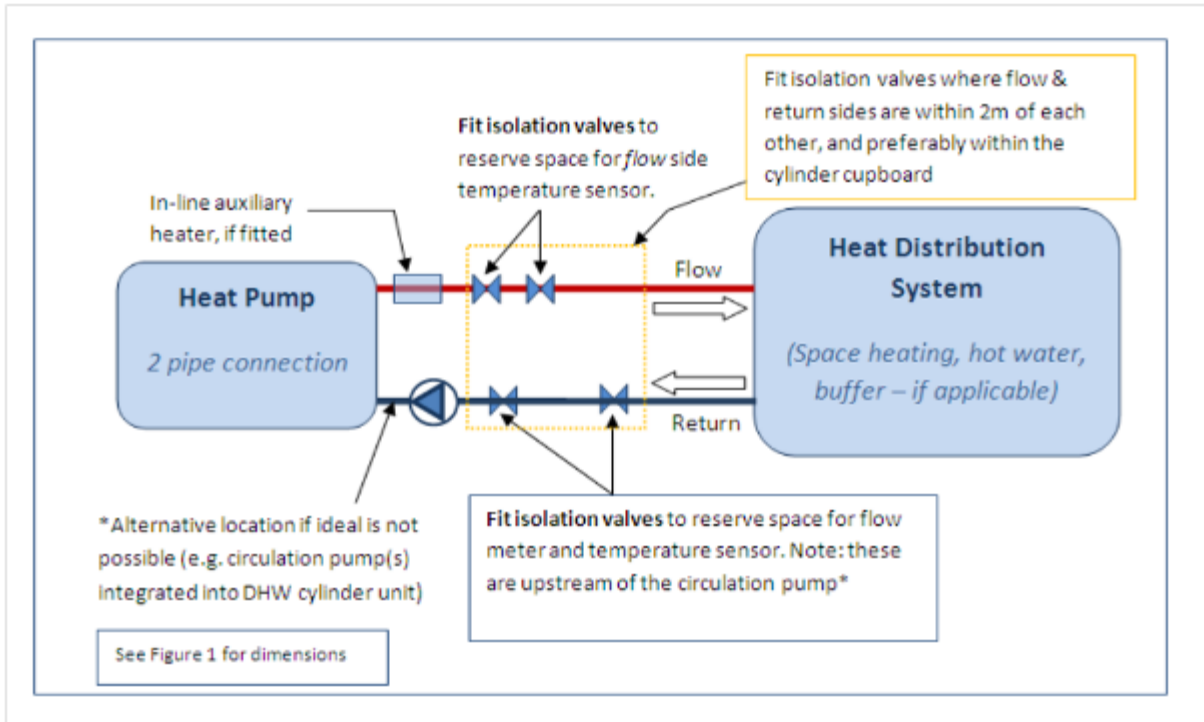

Fig 15 A meter ready installation

4.6 Electrical Installation

The Kensa Compact heat pump range is available in either single or [three phase power supply](#) versions.

Any electrical work required to install or maintain this appliance should be carried out by a suitably qualified electrician in accordance with current IEE regulations

To access the wiring terminals :-

- i. remove the heat pump front cover by unscrewing the 2 x 5mm hex socket screws on each side of the heat pump.
- ii. remove the electronics cover plate by unscrewing the two 3mm cross head screws on the front cover. plate.



Fig 16 Position of Hex screws on the Electronics cover Plate

Cables should enter the unit from below using the cable entry ports provided.

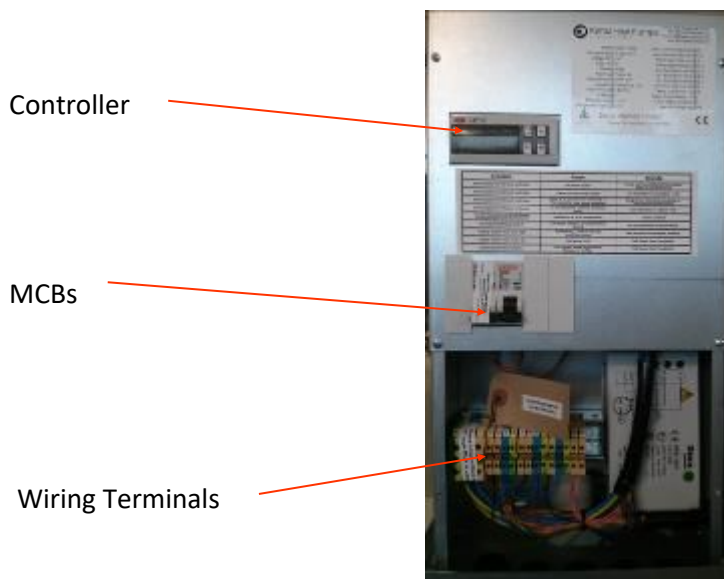

Fig 17 Electrics box with the lower front cover removed

The following sections detail the wiring connections for various applications.

In all wiring diagrams the terminals marked 'Reverse Cycle' change the mode from heating to cooling (If

this option is fitted). This requires a volt free relay, open is heating mode, closed cooling.

The terminals marked 'Fault' are to provide remote indication that a fault has occurred within the heat pump. This is a volt free relay and the internal relay will close if a fault occurs.

Cables should enter the unit from below using the cable entry ports provided. All installations should be fitted with a local isolation switch immediately adjacent to the heat pump. Wiring for the connection between the heat pump and local isolator will be a maximum of 10mm².

Wiring sizes between the consumer unit (fuse box) and local isolator will depend on the length of cable run and how the cable is installed. As this is site dependant, the site electrician should and is responsible for calculating this.

4.6.1 Single Phase

4.6.1.1 Single Under-floor Control Unit

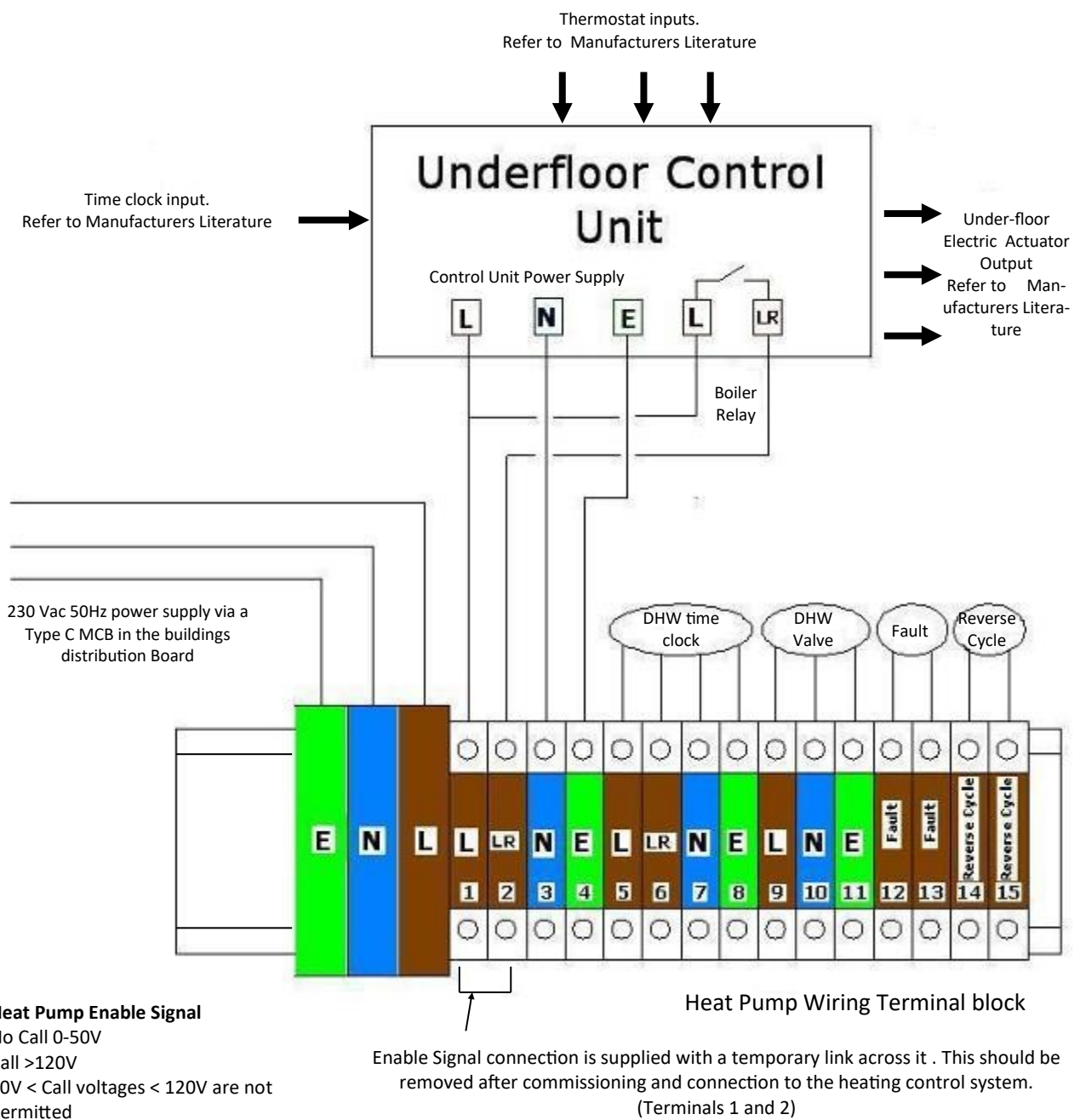
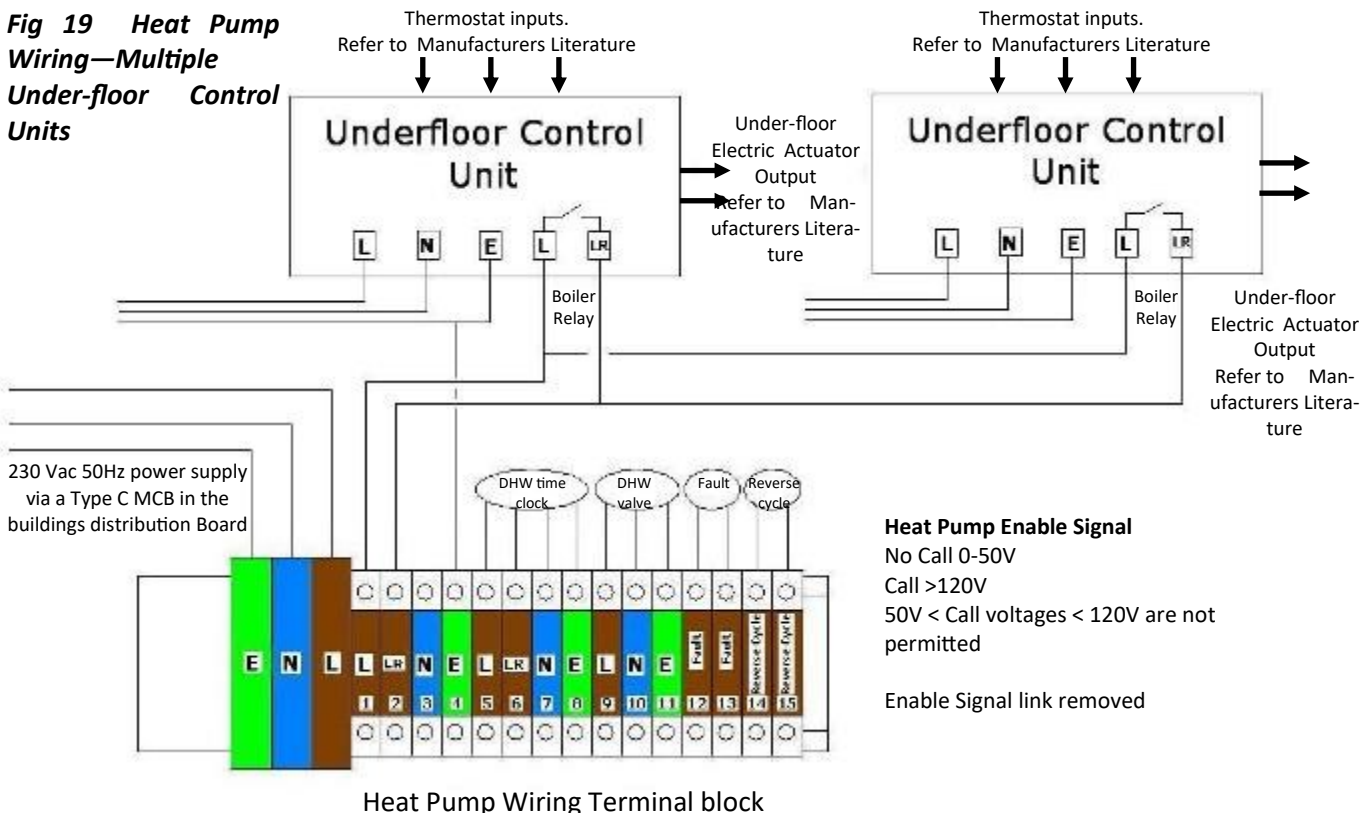

Fig 18 Heat pump wiring—Single Under-floor Manifold

4.6.1.2 Multiple Under-floor Control Units

Fig 19 Heat Pump Wiring—Multiple Under-floor Control Units



4.6.1.3 Radiator with Thermostat

Fig 20 Heat Pump Wiring—Radiators with Thermostat

Heat Pump Enable Signal
 No Call 0-50V
 Call >120V
 50V < Call voltages < 120V are not permitted

Enable Signal link removed

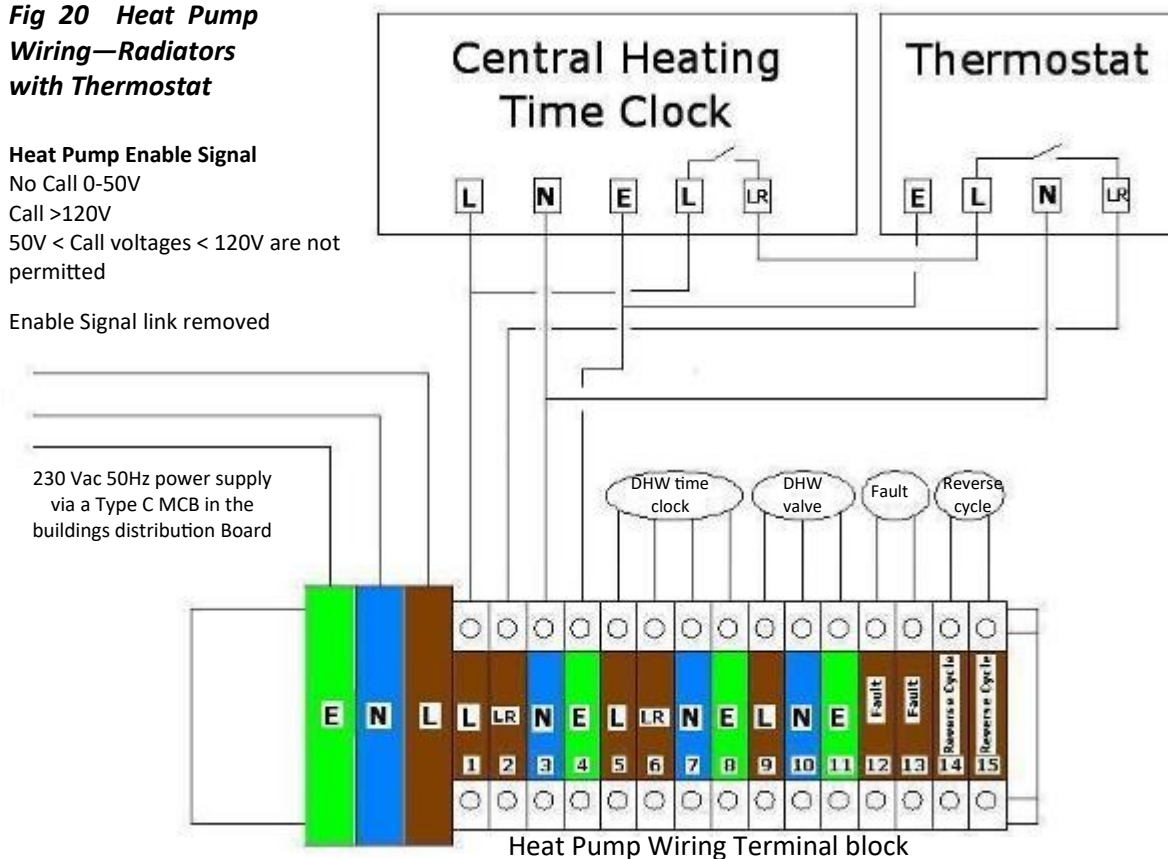

4.6.2 DHW time clock and 3 way diverting valve wiring

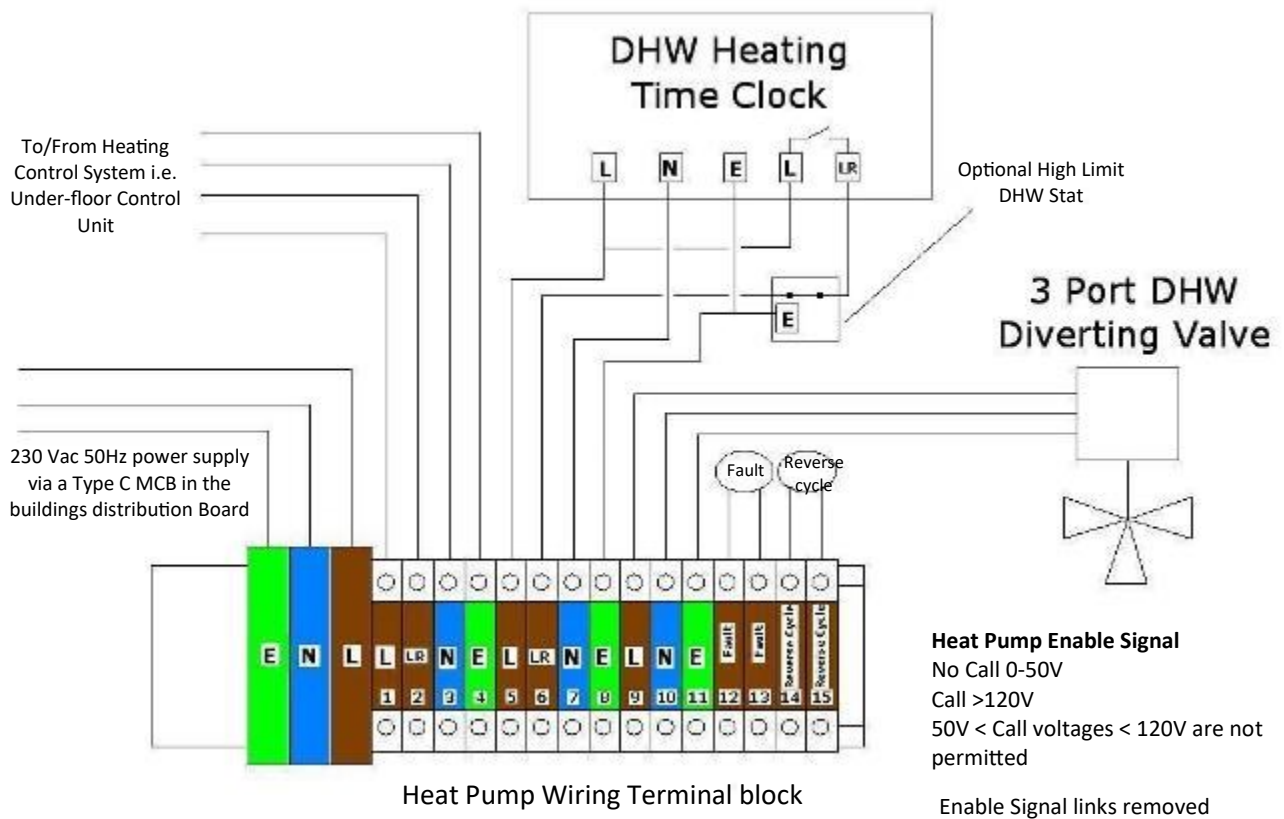

Fig 21 Heat Pump Wiring—DHW

Note: The hot water cylinder high limit stat maybe required to be wired into the live return from the DHW Heating Time Clock.

Note: If DHW option is enabled after commissioning and connection to DHW time clock, remove DHW enable link.

4.6.3 Weather Compensation (Optional)

All Kensa Compact Heat Pumps are supplied with [Weather Compensation](#) as standard. This facility will reduce the return water set-point against a schedule of external ambient temperatures. In more simple terms, the temperature of water flowing into the building's radiators or under-floor heating is reduced in mild weather, which allows the heat pump to run more efficiently. This is particularly important with radiators, as much higher temperatures are required. In cold weather, many people already turn up the temperature of water flowing from their boiler by hand and are therefore weather compensating their heating system manually.

In the UK, the use of banded tariffs such as Economy 7, or more especially Economy 10, makes the use of weather compensation on heat pumps unlikely to give any significant cost savings and can actually increase the cost of running a heat pump. This is because during a banded and cheaper rate of electricity it is desirable to run the heat pump at its maximum heat output so that as much heat is forced into the building as possible, whilst being careful not to overheat it in milder weather.

For this reason, Kensa Heat Pumps are supplied with the required sensors for installation, however the function is disabled in the software. To enable weather compensation (if required) on your heat pump the following settings can be changed within the controller or you can contact our Technical department, who can run through the reprogramming procedure.

The weather compensation sensor is supplied in a small waterproof enclosure.

Fig 22 Weather compensation sensor

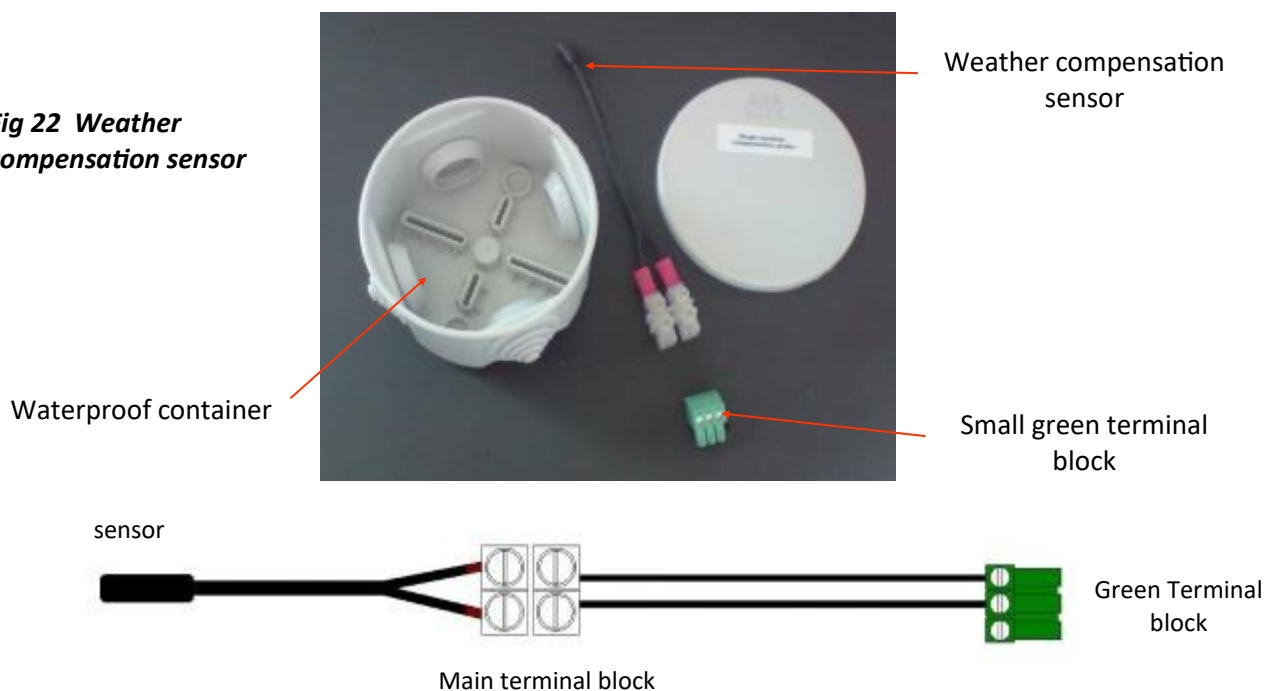

Kensa strongly suggest that the heat pump should be run for at least one week after commissioning, before the weather compensation is activated.

Two sensors are provided with twin compressors and these sensors need to be fixed to a North-facing wall, and connected with 4 core 0.5 mm cable, unshielded, to the heat pump. The cable should be routed inside the heat pump case and left coiled up inside, with the small green terminal block attached. The weather compensation should then be left disabled. If weather compensation is required please follow the procedure over or contact Kensa Technical Department.

Kensa strongly suggest that the heat pump should be run for at least one week after commissioning, before the weather compensation (WC) is activated. This is because WC introduces an additional set of variables, which can complicate and confuse the commissioning process.

The WC outdoor sensor(s) needs to be connected to the Carel(s) in accordance with the instructions supplied in the manual (across terminals GND and B4, no polarity), after the normally connected grey pressure sensor cable is simply left unplugged.

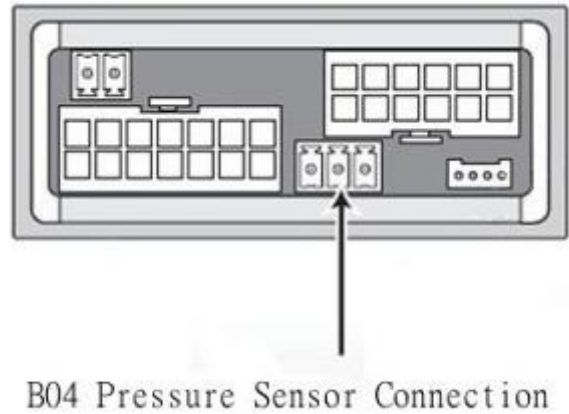

Note. To change any of these parameters, please use access code 66 and finish with the usual PRG, PRG hold PRG routine.

1. Change parameter **/04** to **02**, this tells that Carel that an outdoor temperature sensor is now connected.
2. Change parameter **r3** to the **minimum** return water temperature set point you want the heat pump to operate at during very mild weather. Kensa suggest a setting of 22 (degC) might suit most under-floor heating applications, 30 for radiators (note, when WC is not activated, r3 is the fixed heating set point).
3. Change parameter **r20** to the outdoor temperature set point, **below which** you want the WC to start raising the heating set point. Kensa suggest a setting of around 15 (degC) would suit most property types.
4. Change parameter **r18** to the **maximum** amount of positive deviation (above the r3 setting) you want the WC to allow. The sum of r18 and r3 should not normally exceed 45 for standard temperature models or 55 for high temperature (HT) models.
5. Parameter **r31** is the multiplier of the number of degrees you want the water temperature set point to rise (above r3), for each degree fall in sensed outdoor temperature (below r20). **Please note that r31 must be set to a negative value.** Example: r31 is set to -2, r3 is set to 30, r20 is set to 15 and the outdoor temperature is +13 degC, then the heat pump would heat up to 34 degC return. As the sensed outdoor temperature falls, deviation will grow in a linear fashion until the limit set by r18 is reached. We suggest an r31 value of between -1.0 and -1.5 would suit most property types.

The temperature being measured by the outdoor WC sensor can be seen by viewing **B04**, this should be checked after connection and after the /04 parameter adjustment above.

None of the above adjustments will have any effect on operation in DHW mode.

Weather compensation needs to be 'tuned' carefully to the application and generally should not be used where an 'off peak' tariff is being used to run the heat pump.

To enable weather compensation		
Steps	Action	Display
1	Unplug pressure transducer from the internal Carel controller	
2	Plug weather compensation plug into internal Carel controller	
3	Press and hold SET (or PRG & SEL together on the internal controller) and release when 0 is displayed	0
4	Press and hold the up button, and release when 66 is displayed	66
5	Press SEL	"S-P"
6	Press SEL	"-/-"
7	Press SEL	"-/01-"
8	Press the up arrow until -/04	"-/04-"
9	Press SEL	Default 03
10	Change to 02	02
11	Press SEL	"-/04-"
12	Press PRG	"-/-"
13	Press the up arrow until -r- is displayed	"-r-"
14	Press SEL	"r01"
15	Press up arrow until r03 is displayed	"r03"
16	Press SEL	Default 26
17	Set to 22 for under floor, 30 for radiators	
18	Press SEL	"r03"
19	Press the up arrow until r20 is displayed	"r20"
20	Press SEL	Default 0.0
21	Set to 15	15
22	Press SEL	"r20"
23	Press the down arrow until r18 is displayed	"r18"
24	Press SEL	Default 0.3
25	Set to, 18 for under floor, 15 for radiators, (20 for Radiators High temperature models)	
26	Press SEL	"r18"
27	Press the up arrow until r31 is displayed	"r31"
28	Press SEL	Default 0.0
29	Set to (minus) -1.2	"-1.2"
30	Press SEL	r31
31	Press PRG twice until S-P is displayed	S-P
32	Press and hold PRG until the display returns to normal	
	The weather compensation settings will need to be adjusted over the course of at least one winter	

5. Commissioning

After all mechanical and electrical work has been completed, the following commissioning instructions should be followed.

5.1 Purging the ground array of air.

It is important for correct operation that all the air is removed from the [ground arrays](#). Slinkies consist of a large number of 1 metre diameter loops of 32mm OD pipe and air can collect at the top of these loops. Even vertical (i.e. drilled) arrays can have trapped air and should be purged.

To remove the air from ground arrays, a suitable pump will be required. For [slinkies](#), the longest slinky trench is 50 metres, which will contain a total of approx. 300 metres of pipe. To achieve the minimum velocity required to remove the air, a minimum pump power in excess of 1 kW is required. In addition, the pump needs to have a flow of at least 60 litres per minute against a pressure of at least 1 bar. To achieve this, a multi-stage pump is required.

A normal rising cold water main in a building has insufficient flow to force out this air. Mains water is also “aerated”, so should not be used.

The recommended purge pump is the Clarke SPE1200SS (part no. 051012200). The pump is supplied ready to take a 1” BSP fitting. Two x 1” BSP male to 28 mm compression fittings are required to enable the pump to be connected to the slinky manifold using 28 mm “Speedfit” or similar pipe and elbows. These are readily available from plumbing merchants.

**Fig 23 Clarke
SPE1200SS Purge
Pump**



The Clarke SPE1200SS can achieve as much as 5 bar pressure against a closed valve, so ensure the connections to the pump and manifold are robust.

5.1.1 Purging Procedure for Multiple slinkies.

- i. Remove the plastic blanking plugs, and connect the purge pump to the fill and purge ports on the Slinky manifold, see diagram over leaf. Keep the isolating valve to the heat pump closed. The purge ports can be connected either way round.
- ii. Connect the purge pump to draw from an 80 litre dustbin half filled with clean water. This pump must be capable of circulating 60 litres per minute against a pressure of 1 bar. If the pump’s electrical rating is less than 1 kW, then it is unlikely to be suitable. Kensa only recommend the use of the Clarke SPE1200SS pump as above. The water level in the dustbin will need to be topped up constantly during the following process. The pump may need priming by pouring water into its priming port until it overflows.

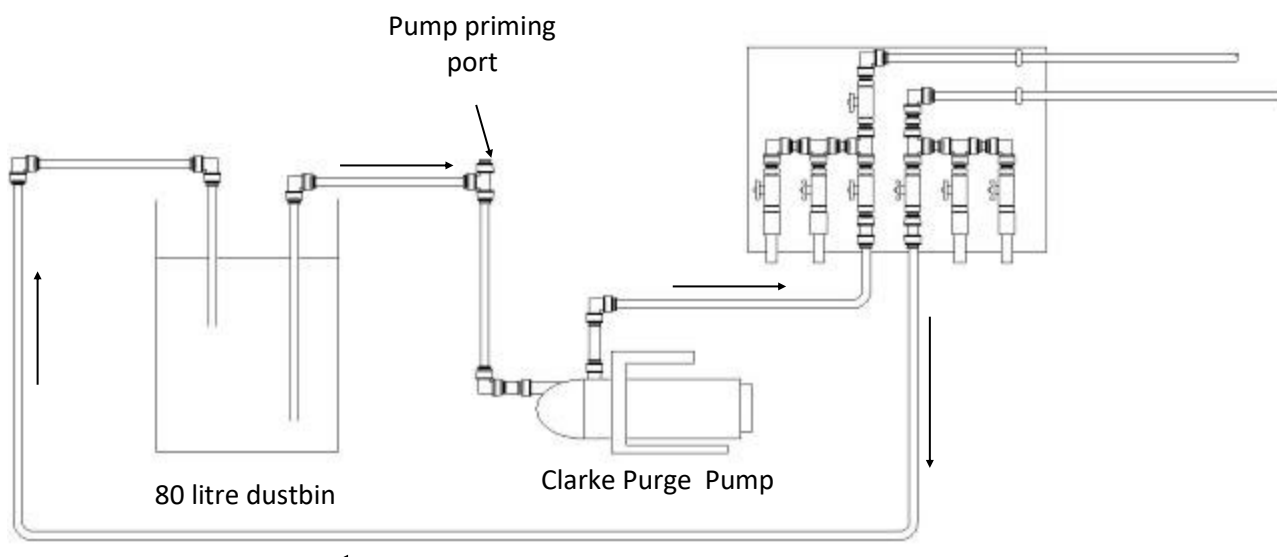

Fig 24 Slinky purging kit connected to a manifold

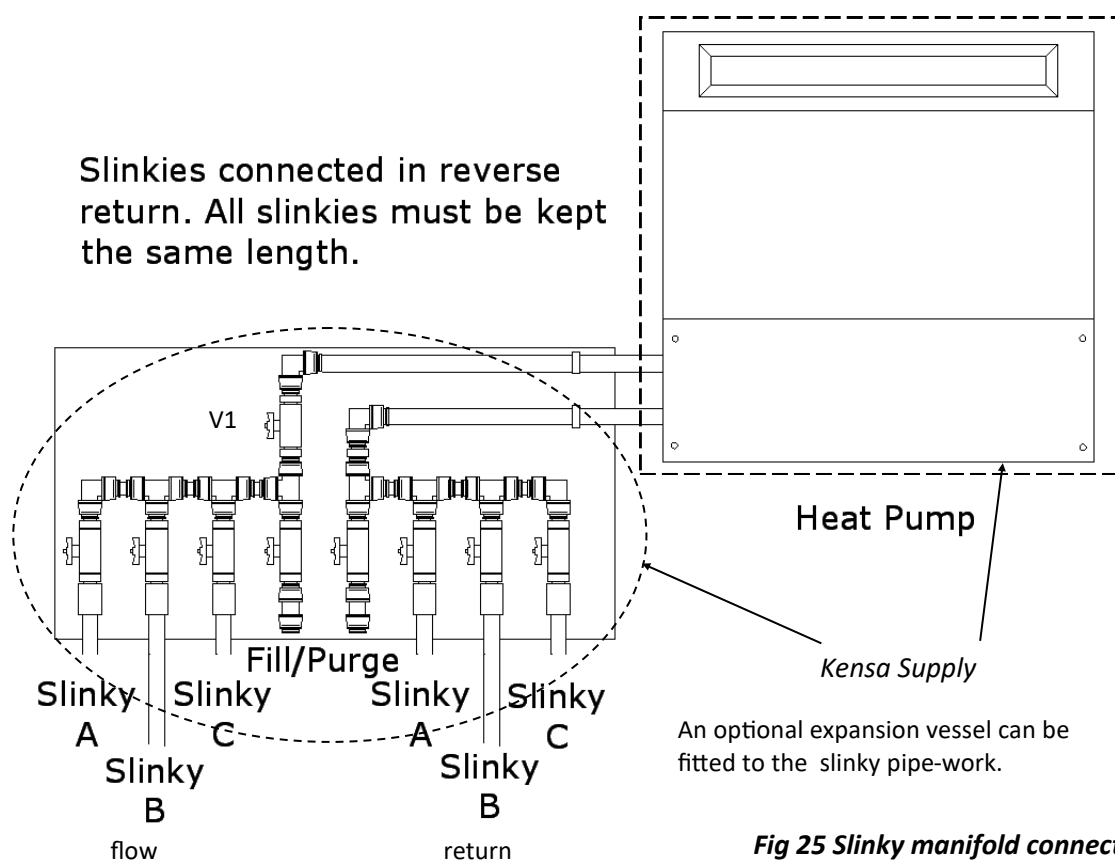

Fig 25 Slinky manifold connections

iii. Place a filter such as a kitchen sieve over the pipe returning water to the dustbin so any debris will be captured. Ensure all valves are closed including the heat pump valve V1. Open the valves on the manifold in the following order (refer to above diagram Fig 25) :-

- a. Open A_{return}
- b. Open A_{flow}
- c. Open both purge valves

Start the purge pump, being careful that the water pipe returning water to the dustbin is secure.

iv. If the water level in the dustbin does not start to drop, then repeat the pump priming. No water

should be flowing through the heat pump or through the other slinkies. The flow rate should be in excess of 30 litres per minute. This can be checked simply by holding a 10 litre bucket to collect water returning from the slinky, and ensuring that it fills in less than 20 seconds. If the flow is less than this, sufficient velocity is not being achieved to displace the air at the tops of the slinky coils.

Fig 26 Purging the Slinkies of Air



Fig 27 Slinkies Purged of Air

- v. After water has circulated for about ten minutes, and no more debris has collected in the sieve, place the return pipe below the water level in the dustbin to ensure all the air has also been expelled (Fig 27). Stop the purge pump and then the valves on the first slinky can then be closed, again ensure that the return pipe into the dustbin is secure. At this stage, the valve to the heat pump should still be closed.
 - c. Close A_{flow}
 - d. Close A_{return}

Repeat the above procedure (steps iii to v) for the next slinky (i.e. slinky B on the diagram).

- vi. When all the slinkies have been purged, change the connections around and re-purge in the opposite direction as per MCS guidelines.
- vii. When all the slinkies have been purged, the valve to the heat pump can be opened, which will purge the heat pump of air - this is likely to be very quick, and great care should be taken that the hose discharging into the dustbin is secure, as any air in the heat pump will be rapidly expelled.
 - e. Close all valves to the slinky pipes.
 - f. Open V1
- vii. Continue purging the heat pump until all the air has been expelled. (No more bubbles are expelled from the return pipe. Fig 27)
- viii. After the air has been removed it is advisable that **before** the antifreeze is added the system is leak tested to BS805 Section 11.3.3.4. (See 5.1.3.1), if this didn't occur when the slinkies were installed.

5.1.2 Adding Antifreeze

The [antifreeze](#) provides protection to the heat pump by preventing the circulating ground fluid from freezing in the heat exchanger. If not added in sufficient quantities the heat pump can freeze and cease working. All antifreeze provided with the order should be added and it is recommended that the quantity is roughly divided between the number of slinkies. This amount of antifreeze is the minimum required for a standard system. If the heat pump and manifold are a distance apart this quantity may need to be increased. Please contact Kensa for further details.

It is very important to purge all the air from the system before adding the antifreeze as it is very difficult to remove the air with the antifreeze in the system due to the higher viscosity of the mixture.

Once the purging of all the air within the slinkies and heat pump has been completed the antifreeze needs to be added.

- i. Open the flow and return valves to one of the slinkies and with the purge pump running, empty some of the water out of the dustbin via the return pipe to the dustbin. This is fresh water and hence can be discharged to drain. The level needs to drop to about 200 to 250mm. Take care that the suction pipe remains covered with water to stop any air being admitted into the system.
- ii. Turn the purge pump off and close both the flow and return valves on the slinky.

- iii. Carefully pour a drum of antifreeze into the dustbin using appropriate handling protection as outlined in the COSH. Allow the solution to settle for a few moments to allow any trapped air to escape.
- iv. Open the valve V1 to the heat pump and start the purge pump to circulate the antifreeze around the system. Leave the pump running until antifreeze is seen returning to the dustbin. The amount of time this will take depends upon the length of the header pipe.
- v. Close the valve to the heat pump and turn the purge pump off.
- vi. Open the first slinky flow and return valve and with the return pipe inside of the dustbin start the purge pump. Once the return discharge runs clear, i.e. It's discharging fresh water, move the return pipe out of the dustbin and discharge this fresh water to drain until the antifreeze level within the dustbin drops to approximately 200-250mm. Take care that the suction pipe remains covered with water to stop any air being admitted into the system. (Depending on the length of header pipe additional antifreeze might be required to be added at this stage). The discharge pipe can then be placed back into the dustbin and the purge pump should be run for about 5-10mins and then turned off.
- vii. Close the slinky valves; add the next quantity of antifreeze to the dustbin and repeat the above steps vi and vii for each individual slinky.

5.1.3 Pressurising the system.

- i. Open all valves EXCEPT THE DISCHARGE PURGE CONNECTION. Keep a close eye on the level of water in the dustbin and start the purge pump. This should pressurise the whole system. If the level of water drops significantly this indicates the system hasn't been correctly purged of air and needs to be re-purged.
- ii. Close the fill purge valve on the slinky manifold with the pump running, so that the ground array is left under pressure.
- iii. Most purge pumps will attain around 5 bar, and the circuit should be left at this pressure for a minimum of 15 mins, as any leaks will become immediately apparent. The pressure will slowly fall as the pipes in the ground arrays slowly expand in the coming months, and may need topping up using the cold fill system provided.
- iv. Remove the purging equipment. Replace the plastic blanking plugs in the slinky manifold purge connections.

There should be approximately 200-250mm of water/antifreeze mix within the dustbin which can be poured back into an empty drum and disposed off according to the disposal instructions in section 8 or retained for topping up the system.

To mix the antifreeze around the ground arrays thoroughly, it is advised that the ground array circulation pump is turned on via the 6 amp MCB on the heat pump. (Note DO NOT TURN THE COMPRESSOR 25 amp MCB ON). This ground array circulation pump should be left running for two to three hours to ensure the antifreeze is mixed in all the slinkies and the heat pump. (Note: - the floor pump will also run.)

5.1.3.1 Pressure Testing in accordance to BS805 Section 11.3.3.4

In accordance with MCS Guidelines, leak tightness (pressure) testing has to follow the EN 805 prescriptions in section 11.3.3.4. This test should be carried out after the ground arrays have been purged but before the antifreeze is added. For polyethylene (PE) tubes, the pressure testing has to be carried out as a 'compression test'. An overpressure (inside-outside) is applied to the pipe over the whole length. This step inflates slightly the PE pipe over its whole length. Then a sudden pressure drop of around 10% of the testing pressure is applied. This pressure drop allows the pipe to compress again. If the pipe is tight, a pressure increase is measured. This test should only be carried out on the ground arrays with the heat pump isolated from the test.

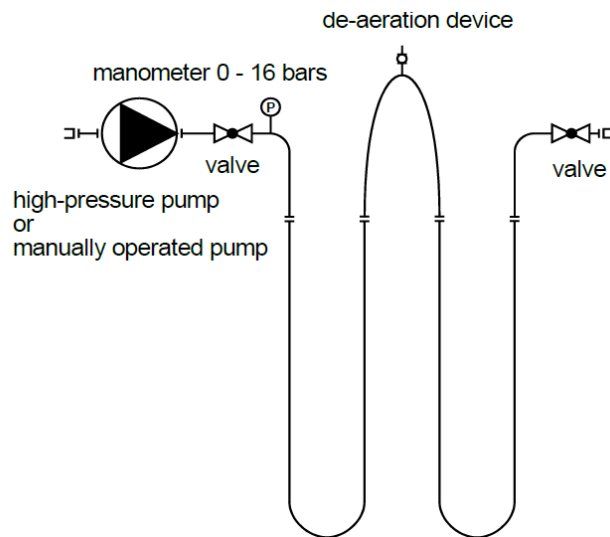

Fig 28 Leak Tightness Configuration

To perform such a test, the following equipment is needed:

- A high-pressure pump or a manually operated pump
- 2 stop valves
- 1 manometer 0 -16 bar
- A de-aeration device (if any point of the ground array is at a high point where air can collect)

Test procedure in detail (Fig. 30):

- 1 h Idle period. No overpressure is applied to the tube . ①
- Apply the test pressure. For PE100/PN16/SDR11 ground arrays this should be > 7.5 barg. If the heat pump is within the pressure test this should be less than 10 barg. For other materials follow the manufacturer's specification ②
- 10 min Keep up pressure test ③
- 1 h Idle period. The tube is going to expand over the whole length
- Pressure measurement. The pressure drop may not exceed the manufacturer's specifications ④
- Sudden pressure drop of at least 10% of the test pressure ⑤
- 10 mins. First pressure measurement ⑥ A
- 20 mins. Second pressure measurement ⑥ B
- 30 mins. Third and final pressure measurement ⑥ C

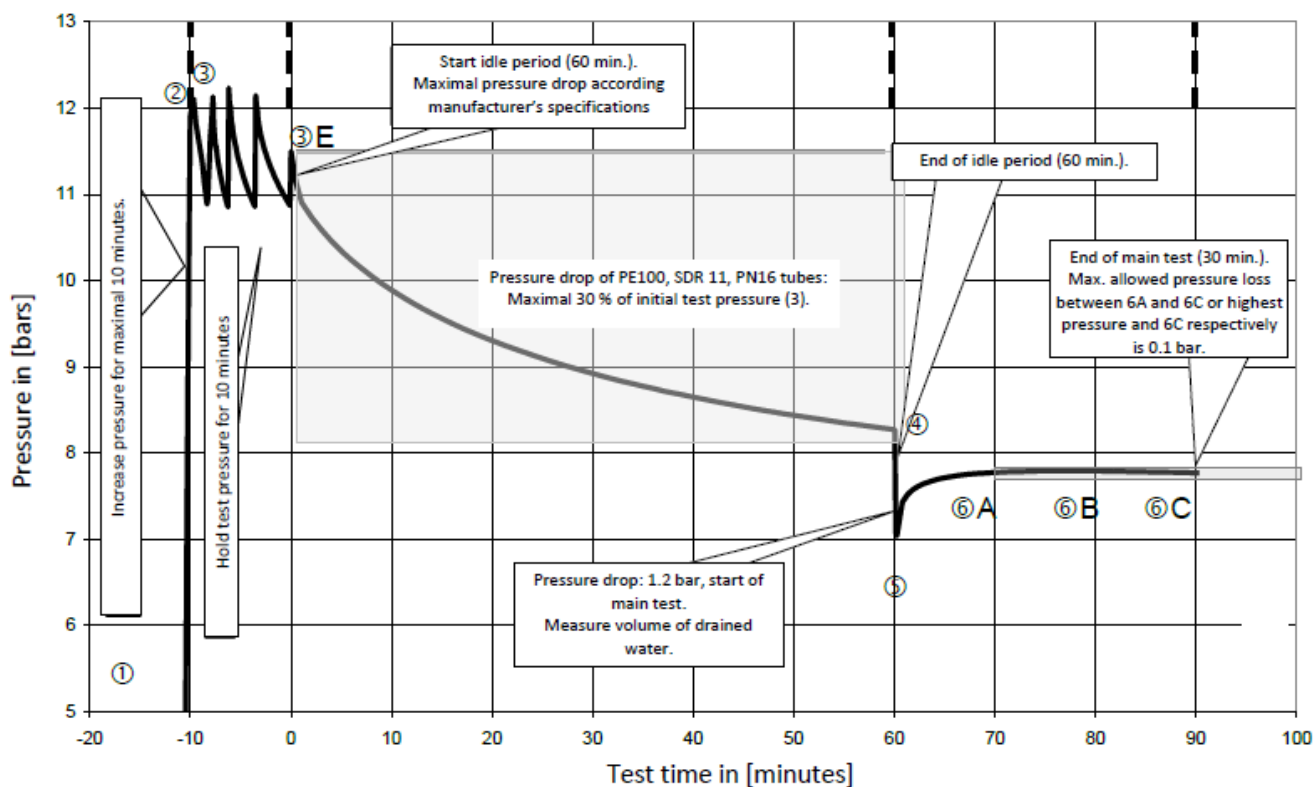

Fig 29 Graphical Test Procedure

The ground array has passed the test if the pressure difference (pressure drop) between (6)C and (6)A does not exceed 0.1 bar.

The test should not be conducted in cold weather, when there is a risk of freezing.

5.1.4 Testing of Antifreeze Concentration

It is important that the concentration of the antifreeze within the ground arrays should be a minimum of a protection level of -10°C (minimum 22% by volume, Refractive Index 1.356). Concentrations below this could cause an A1 alarm and the heat pump to cease operation during severe prolonged cold weather.

The antifreeze concentration should be tested with a refractometer .

The concentration of antifreeze is required for the commissioning certificate and it is advised that this figure is noted in the settings table. A sample of the fluid can be obtained from the ground side Schrader valve as shown in Fig 31. To comply with MCS guidelines two random samples of anti-freeze concentration should be taken when the unit is commissioned.

5.1.5 Heating distribution and load side purging

- i. Find the cold fill for the heating system and open the valve on the heating system to allow water into the heating system and the Compact.
- ii. Follow the manufacturer's procedures for purging the heating system.
- iii. For any systems that involves cooling, antifreeze (minimum 22% by volume, Refractive Index 1.356) must be added to the distribution load side.
- iv. Remove the cap from the heating pump bleed port and depress the Schrader valve using a small screw driver, as shown in the illustration (below).



Fig 30 Location of Heat Pump Schrader Valves

- v. Alternatively, the Schrader valve core can be unscrewed completely using a car valve core remover and a 10 mm internal diameter plastic pipe placed on the outside of the valve to allow any water or air to be vented into a bucket.
- vi. When a constant stream of water comes from the valve the pump will have been bled. This procedure needs to be repeated at intervals during the commissioning procedure if there is any air in the heating system. Place the cap back on the bleed valve.

We recommend a central heating inhibitor is added to the heating water in the heating distribution circuit.

5.1.6 Reassembling the Heat Pump

- i. Ensure all tools and materials are removed from the inside of the unit.
- ii. Reposition the front cover
- iii. Using the 4 x 5mm hex socket screws secure the front cover in place.

5.2 Heat Pump Operation

Prior to use: -

- i. Turn off the power supply at the local isolator
- ii. Unscrew the 4 x 5mm hex socket screws on either side of the front panel (2 each side). Remove the front panel.
- iii. Check that the ground pressure gauge reads at least 0.3 bar. If the pressure is lower than this, open the mains cold water supply valve (fitted outside the case) fully until the gauge reads at least 1.8 bar, at which point a “click” will be heard. Close the mains cold water supply valve fully.
- iv. Check that the heating distribution system pressure gauge reads at least 0.3 bar. If the pressure is lower than this, find the mains cold water supply valve and pressurize the system until the gauge reads at least 1.8 bar, at which point a “click” will be heard. Close the mains cold water supply valve fully. Reassemble the front panel taking care to ensure that the 4 x hex screws are located correctly. A purge pump can achieve pressures of 5 bar and it is acceptable that the ground arrays are left at this pressure.
- v. Turn on the power supply at the local isolator and program the external time clock / thermostat.

5.3 Turning the Heat Pump on for the first time.

- i. Make sure the impellers in both the ground and heating distribution water pumps are free to turn by removing the stainless steel screws (if fitted) in the centre of each water pump and inserting a flat-bladed screwdriver to spin the impellor. Do not try to spin the impellor with the power on.

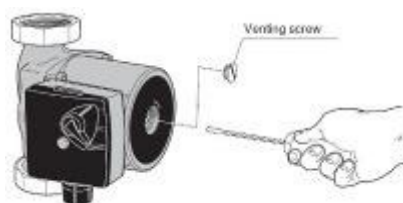

Fig 31 Spinning the pump

- ii. Turn both the 6 Amp MCBs on to enable the controls and water pumps to operate. Operating this MCB should result in a sudden sharp change in pressure on the under-floor pressure gauge and indicates that the pump is operational. Shortly after operating this MCB, the compressor contactor should engage. This will result in a sudden sharp change of pressure indicated on the ground array pressure gauge and this indicates that the ground array water pump is operational. **DO NOT operate the compressor MCB until Kensa Heat Pumps has been contacted and flow has been confirmed around the system.** Failure to do this will cause the unit to freeze and may invalidate the warranty.
- iii. The controller display will read the temperature of the water returning from the heating system. If the error Tp is displayed, then the heat pump will not run until both heating distribution and ground circuits are above 1.8 bar pressure.
- iv. The commissioning of the heat pump will be carried out remotely (via phone) by a Kensa commissioning engineer and a heat pump commissioning certificate and checklist issued on completion. Please contact Kensa Heat Pumps to book a commissioning call.
- v. After commissioning and connection to the heating control system (with the power isolated) remove the enable link between terminals 1 and 2.

5.4 Altering the flow temperature from the heat pump

Each heat pump has a dedicated display which can be interrogated to view various parameters, alter the heat pump outlet flow temperature and indicate faults/alarms. Twin compressors have two displays one for each compressor.



n.b. the numbers above refer to the points below.

Fig 32 Heat Pump Display

The display normally reads the temperature of the water returning from the heating distribution system. The controller will turn the heat pump off once a pre-set temperature of water returning from the heating system has been achieved. This setting is normally 30 °C for the left hand compressor and 31°C for the right. These are typical return temperatures for an under-floor application. In DHW mode, the display shows the return temperature from the DHW circuit and the light to the right of the controller will be lit.

The Kensa Compact Range of heat pumps are delivered with the software pre-configured for a typical under-floor mounted in screed application.

1. The display on the controller indicates the return temperature of the under-floor circuit.
2. The left hand symbols, sun, (top left) and frost, (bottom left) indicate heating & cooling respectively (Heating only heat pumps will only use the sun symbol and cooling heat pumps only the frost symbol. Reverse cycle machines will use both symbols, the one being displayed being dependant on the operating mode selected at the time.)

 Sun symbol—heating mode

 Frost symbol—cooling mode

3. A number “1” will appear top right of controller this is to indicate compressor number, if the number “1” is flashing the internal timer is activated and compressor is waiting to run. When the compressor is running the number “1” and the compressor run symbol will be on.



Compressor running

A flashing error code may appear if there is a fault with the heat pump, the most common will be: -

Alarm	Description
TP	Low water pressure (ground or heating distribution)
HP	High gas pressure caused by low or no flow on the heating distribution circuit.
LP	Low gas pressure fault (can occur temporarily on first start up). Call Kensa Technical Department.
A1	Anti freeze alarm, ground getting too cold / insufficient anti freeze/ unit not commissioned correctly/ low flow around ground arrays.

(See Fault Finding Section 6 for further details)

5.4.1 To read flow temperatures and refrigerant pressures

Using the display it is possible to interrogate the heat pump to read flow temperatures and refrigerant pressures. The left hand display reads temperatures and refrigerant pressures in compressor one and the right hand controller compressor two.

To read flow temperatures and refrigerant pressures, on each controller: -

- 1 Press and hold SEL until -/- is displayed
- 2 Press the UP arrow until -b- is displayed
- 3 Press SEL and b01 is displayed
- 4 Press SEL
- 5 Temperature of water returning from the under-floor is displayed = b01
- 6 Press SEL
- 7 Press the UP arrow once until b02 is displayed
- 8 Press SEL
- 9 Temperature of water returning from ground arrays is displayed = b02
- 10 Press SEL
- 11 Press the UP arrow once until b03 is displayed
- 12 Press SEL
- 13 Temperature of water going out to the ground arrays is displayed = b03
- 14 Press SEL
- 15 Press the UP arrow once until b04 is displayed
- 16 Press SEL
- 17 Refrigerant pressure (in Bar) is displayed = b04
- 18 Press SEL
- 19 Press PRG twice until S-P is displayed
- 20 Press and hold PRG until the display returns to normal

5.4.2 To change the heat pump return flow temperatures.

Heat pumps are generally controlled on the return temperature from the heating distribution system and

work on a temperature differential of approximately 5 degrees, i.e. if the return temperature set point is 30°C the actual flow temperature out of the heat pump is approximately 35°C.

The outlet flow temperature of the heat pump determines the efficiency of the heat pump.

For under-floor systems mounted in screed a flow temperature of 35°C is generally suitable, therefore the return temperature should be set at 30°C/31°C. However for joisted systems or systems with insulative floor coverings then a higher flow temperature may be required and hence the return flow temperature set point may need to be increased.

For radiator systems a flow temperature of 50°C is generally required. This means the return flow temperature set point should be set to approximately 45°C

For twin compressor units both controllers will need to be set with new return flow temperatures. The right hand controller generally has a return set temperature one degree higher than the left hand controller.

Warning :- Increasing the outlet flow temperature of the heat pump will result in the unit operating at a lower efficiency with higher fuel bills.

Warning :- for under-floor systems do not increase the outlet flow temperature until the screed that the under-floor is mounted in is fully dry.

Programming can be carried out on either the upper external controller or the lower controller within the heat pump.

Changing the flow temperatures is protected by a passcode to prevent unauthorised changes. This passcode is 11 and not changeable.

- 1 For the upper external controller, press and hold SET until 0 is displayed. For the lower controller within the heat pump, press and hold SEL and PRG together until 0 is displayed.
- 2 Using the UP arrow increase the displayed number to 11
- 3 Press SEL and S-P is displayed
- 4 Press SEL and -/- is displayed
- 5 Press the UP arrow until -r- is displayed
- 6 Press SEL and r01 is displayed
- 7 Press the UP arrow until r03 is displayed
- 8 Press SEL
- 9 The return water temperature set point is displayed
- 10 Press the UP or DOWN arrows to change the set point
- 11 Press SEL
- 12 Press PRG twice until S-P is displayed
- 13 Press and hold PRG until the display returns to normal

Both controllers on either side need to be altered.

It is advised that any settings that are changed are noted within Section 9 'Heat Pump Settings Sheet' page 44.

6. Fault Finding

Many faults which occur on commissioning are found to be due to incorrect wiring or setting up, therefore it is recommended that a thorough check is carried out should there be a problem.

Symptom	Possible Cause	Action
Blank display on software controller	No power supply	Check wall mounted electrical isolator switch or call electrician
	Controls MCB tripped	Call electrician to investigate cause
	There is no call from the time-clock or thermostat for heat pump operation	Programme time-clock according to manufacturer's instructions
Compressor not running but display reading temperature near set point	Heat pump is up to temperature	No fault
Display flashes fault code tP	Low water pressure in the ground or heating system side due to pipe relaxation or other pressure loss.	Check the pressure gauges below the two water pumps. The pressures should be between 1 and 2 bar. If below this, the pressure needs to be increased above 1.8 bar To increase the pressure in either circuit, the cold fill valve will need to be opened. The Ground cold fill is provided with every Kensa heat pump, and is found on the right hand side of the heat pump, underneath. The heating distribution system should have it's own fill point.
Display flashes fault code HP	Overheat warning. No or low flow around heating distribution circuit because of air in water pump, or stuck water pump impellor, or heating distribution system valves/ actuators closed.	Bleed the heating distribution system pump within the heat pump, using the schrader valve above the pump. (See Fig 28). Check that the water pumps are operational and spin the impellers. (See section 5.3)
	HP can also be temporarily displayed when the heat pump reverts from DHW to space heating mode.	No action
Display flashes fault code LP	Low gas pressure in machine. Can occur simultaneously with an A1 alarm.	Check that the water pumps are operational and spin the impellers (see section 5.3) If symptom persists outside of the two listed circumstances, contact Kensa Technical department.
	Can occur temporarily on first start up when unit is new or after a long period out of use.	No action
	Insufficient antifreeze added and heat pump frozen.	Allow heat pump to defrost and add the correct antifreeze quantity.
Display flashes fault code A1	Freeze protection system activated. Low or no water flow on the ground (cold) side of the machine. Can also occur after many months of running in very cold weather.	Check antifreeze has been added and unit commissioned correctly. Check that the water pumps are operational and spin the impellers (see section 5.3) Ensure no flow restrictions and wait approximately 4 hours (with the machine turned off) for automatic reset.
Display flashes fault code E1, E2, E3 or E4	Loss of contact with probes inside heat pump. E4 could be loss of contact with weather compensation sensor	Refer to Kensa Technical department

7. Warranty

The Kensa Compact Ground Source heat pump is designed and built to the highest standard and as such is guaranteed for 5 years for parts from the date of commissioning or 5 ½ years from the date of manufacture (excluding the internal water pumps and electrical components), whichever is shorter. Internal water pumps (ground and load side) and electrical components are guaranteed for 2 years for parts from the date of commissioning or 2 ½ years from the date of manufacturer, whichever is shorter.

7.1 Terms and Conditions.

7.1.1 Persons covered by the Warranty

The Warranty applies to the original purchaser and any subsequent owner of the item.

7.1.2 Validity period of the Warranty

The guarantee period (excluding the water pumps and electrical components) is five years calculated from the commissioning date stated on the commissioning certificate or 5 ½ years from the date of manufacture, whichever is shorter. For the water pumps and electrical components it is 2 years from the commissioning date stated on the commissioning certificate or 2 ½ years from the date of manufacture, whichever is shorter.

7.1.3 Scope

Kensa Heat Pumps Ltd warrants to the original purchaser (“Buyer”) that all parts (“Parts”) of the Kensa Compact Ground Source Heat Pump, excluding accessories, shall be merchantable and free from defects in materials and workmanship appearing under normal working conditions.

Kensa Heat Pumps Ltd will, at its option and without charge to the Buyer, replace or repair any Parts which cause the Kensa Compact Ground Source Heat Pump to be inoperable; however, if Kensa Heat Pumps Ltd elects to provide replacement Parts, it shall not be obligated to install such replacement Parts and the Buyer shall be responsible for all other costs, including, but not limited to, shipping fees and expenses.

The warranty applies to faults originating inside the item.

7.1.4 General exceptions

Compensation is not provided for:

- consequential losses
- damage caused by normal wear and tear, inadequate maintenance or care
- damage caused by freezing
- damage of the unit due to non-approved or incorrect quantities of antifreeze being used in the ground side, incorrect flow rates or air in the system
- damage caused by power surges, incorrect supply voltage or lightning strikes.
- cost of inspecting, adjusting or cleaning the item, unless this relates to damage that is eligible for compensation
- minor damage (e.g. scratches and marks) that does not affect the operation of the item
- damage covered by insurance
- indirect damage
- loss or damage caused by gross negligence or intent, misappropriation, fraud or similar crime against property, breach of trust or fraudulent conversion.
- products that have been: altered; subject to misuse, negligence, accidental damage, abnormal use or service; operated or installed in a manner contrary to Kensa Heat Pumps Ltd published or written instructions.

-products subjected to abrasion or corrosion

-products operated in connection with any liquid source that contains impurities which are corrosive to copper

-products operated in a temperature range inconsistent with Kensa Heat Pumps Ltd's published or written recommendations

7.1.5 Care of Duty

The product must be handled with normal care and attention to minimise the risk of damage or loss.

7.1.6 In the event of Damage

The installing contractor ("Contractor"), or, if the installing Contractor is not available, Kensa Heat Pumps Ltd must be notified of any damage immediately and no later than six months after you first became aware of the damage. The commissioning certificate received on installation should be appended to the claim. If a claim for compensation is made after the deadline specified above or if a commissioning certificate cannot be produced, the guarantee shall not apply.

7.1.7 Replacement Parts

Kensa Heat Pumps Ltd's warranty obligations with respect to replacement parts are identical to those with respect to original parts; provided, however, in no event shall the warranty term for such replacement parts extend beyond the term established by the commencement date (i.e. commissioning date) of the warranty under which Kensa Heat Pumps Ltd was obligated to provide such replacement parts. Kensa Heat Pumps Ltd shall have the right to retain possession or dispose of any parts replaced by it.

This page is left intentionally blank

Introduction

Safety information

General product information

Installation

Installation schematics

Installation mechanical

Installation electrical

Commissioning

Fault Finding

Warranty

Heat Pump settings sheet

8. Heat Pump Settings Sheet

Type of ground arrays	
Ground Arrays purged	
Ground arrays leak tested according to BS805 Section 11.3.3.4	Yes / No
Antifreeze quantity	
Antifreeze concentration	Sample 1 Sample 2
Serial Number	
Visual Inspection	
Feet level on floor	
Visual check of site wiring	
Software operating	
Software errors	
Heating Status	
Ground water pressure	
Under-floor water pressure	
Make of under-floor heating	
Manifolds	
Any UFH water pumps	
Control philosophy	
B01 under-floor return temperature	
B02 ground return temperature	
B03 ground feed temperature	
B04 evaporating pressure	

Comments:

Installed by:-

Date:-

Tel:-